

# MANIGLIE & ACCESSORI



**GAROFOLI  
GROUP**

## MANIGLIE & ACCESSORI



*J. Garofoli*

# Made in Italy, dal 1968.

Il Gruppo Garofoli si colloca tra i leader mondiali nella progettazione, costruzione e commercializzazione di porte per interni, con particolare specializzazione per le porte in legno massiccio. Il Gruppo, guidato dal fondatore Fernando Garofoli, si posiziona nel segmento più alto del mercato di riferimento. Oggi i suoi prodotti sono diventati concreti simboli d'eccellenza del Made in Italy nel mondo. Dalle porte classiche in legno massello ai prodotti di design in alluminio, il Gruppo Garofoli è in grado di rispondere alle richieste di un mercato sempre più evoluto, seguendo i criteri consoni all'interior design di ultima generazione.



The Garofoli Group is one of the world leaders in the design, construction and sale of interior doors and is particularly specialised in solid wood doors. The Group, led by founder Fernando Garofoli, is positioned at the highest end of the reference market. Today, its products are concrete symbols of the excellence of "Made in Italy" in the world today. From classic doors in solid wood to designer products in aluminium, Garofoli Group can meet the demands of an increasingly sophisticated market, using criteria in line with the latest in interior design.

Le Groupe Garofoli se place parmi les leaders mondiaux pour la conception, la réalisation et la commercialisation de portes d'intérieur, se spécialisant dans les portes en bois massif. Sous la houlette de son fondateur, Fernando Garofoli, le Groupe se positionne dans le haut de gamme du marché de référence. Aujourd'hui, ses produits sont des symboles d'excellence concrets du "Made in Italy" dans le monde. Des portes classiques en bois massif aux produits design en aluminium, le Groupe Garofoli est en mesure de répondre aux exigences d'un marché en évolution constante, en suivant les dernières tendances en matière de design d'intérieur.

El Grupo Garofoli se encuentra entre los líderes mundiales en materia de diseño, fabricación y comercialización de puertas para interiores, especialmente de madera maciza. Bajo la dirección de su fundador Fernando Garofoli, el grupo se propone al segmento más alto del mercado de referencia. Sus productos han llegado a ser actualmente un símbolo de excelencia del "Made in Italy" a nivel mundial. Con su producción, que abarca desde las puertas clásicas de madera maciza hasta los productos de diseño contemporáneo en aluminio, el Grupo Garofoli responde plenamente a las demandas de un mercado cada vez más avanzado siguiendo las pautas del interiorismo de última generación.

Die Gruppe Garofoli zählt zu den weltweit führenden Namen bei der Planung, der Herstellung und dem Vertrieb von Innentüren, und hat sich im Besonderen auf Massivholztüren spezialisiert. Unter der bewährten Führung des Gründers Fernando Garofoli werden hochwertige Produkte für die gehobene Marktkategorie angeboten. Türen von Garofoli repräsentieren heute auf der ganzen Welt mit Erfolg italienisches Design und italienische Qualität. Von klassischen Massivholztüren bis hin zu Designobjekten aus Aluminium – bei Garofoli findet der anspruchsvolle Kunde immer genau das, was er sucht und braucht. Denn Gruppe Garofoli trägt den ständig wachsenden Ansprüchen des Marktes Rechnung, und orientiert sich dabei bewusst an den Kriterien des modernen Interior Design.

Группа Garofoli является одним из мировых лидеров в разработке, производстве и сбыте межкомнатных дверей и специализируется в изготовлении дверей из массивного дерева. Под руководством его основателя, Фернандо Гарофоли, Группа находится в самом высшем сегменте рынка дверей. Сегодня ее продукция превратилась в конкретное воплощение преимущества итальянского стиля "Made in Italy" во всем мире. Предлагая классические двери из массивного дерева рядом с дизайнерскими дверьми из стали с щеточной обработкой и алюминия, компания Garofoli Group может удовлетворять требования все более взыскательного рынка, придерживаясь критериев самого современного дизайна интерьеров.

› indice | index | índice | Index | индекс



8 maniglie | handles | poignées | manillas | Griffe | ручки



60 maniglia playa | handle playa | poignée playa | manilla playa | griff playa | ручки Playa



64 pomoli | knobs | boutons | pomos | Knäufe | круглые ручки



70 kit pomolo+maniglia | knob+handle kit | kit bouton+poignée | kit pomo+manilla | Knauf+Griff | комплект круглая ручка+ручка



73 maniglioni | large handles | grandes poignées | manillones | große Griffe | ручки



82 vaschette - maniglie a vaschetta | bowls - bowl-type handles | cuvettes - poignées cuvettes | rectangular empotrado | Schalen - Schalengriffe | шайба - ручка на шайбе



89 occhiello tiraporta | ring pull | tire-doigt | uñero circular | griffmulden | петля-ручка



92 accessori | accessory | accessoires | accesorios | zubehör | аксессуары

MANIGLIE PER PORTE VERSIONE A BATTENTE, A LIBRO MIX, ROTOTRASLANTE | HANDLES FOR HINGED, MIX FOLDING AND PIVOT SLIDING DOOR VERSIONS | POIGNÉES POUR PORTES VERSION À BATTANT, PLIANTE MIX, PIVOTANTE | MANILLAS PARA PUERTAS DE TIPO BATIENDE, LIBRO MIX, ROTOTRASLANTE | GRIFFE FÜR FLÜGELTÜREN, FALTTÜREN MIX UND DREHSCHIEBETÜREN | РУЧКИ ДЛЯ РАСПАШНЫХ ДВЕРЕЙ, ДЛЯ ДВЕРЕЙ-КНИЖКИ MIX, ПОВОРОТНО-РАЗДВИЖНЫХ АВТОМАТИЧЕСКИХ ДВЕРЕЙ

				
pag. 8 110&LODE 'BAROCCO'	pag. 9 110&LODE 'DECAPÈ'	pag. 10 110&LODE 'LISCIA'	pag. 11 AMBRA	pag. 12 AMBRA ALLUNGATA
				
pag. 13 AREA 51	pag. 14 AREA 52	pag. 15 ATLANTA	pag. 16 BASE	pag. 17 BLADE
				
pag. 18 BOLT	pag. 19 BOLT WOOD	pag. 20 CLASSICA 'NOSTRO MODELLO'	pag. 21 DUE	pag. 22 DOLLY
				
pag. 23 ECO ICE	pag. 24 EIDOS	pag. 25 FLOW	pag. 26 GOLF	pag. 27 ICE 2018
				
pag. 28 ICON	pag. 30 INFINITO	pag. 32 INFINITO PLACCA LUNGA	pag. 34 KALÈ	pag. 35 LARIO
				
pag. 36 LIFE	pag. 37 LINK	pag. 38 LUCE	pag. 39 LUCE ORIZZONTALE	pag. 40 LUCIA
				
pag. 41 MILOX	pag. 42 MILENA	pag. 43 PLUSS 2018	pag. 44 PURE	pag. 45 QUADRA
				
pag. 46 SIRIO	pag. 47 SMART	pag. 48 SPRINT	pag. 49 SQUADRA	pag. 50 TIMELESS
				
pag. 52 TUCE GLASS	pag. 53 TUCE	pag. 54 UNO	pag. 55 WING	pag. 56 WINNER WOOD
				
pag. 57 XOSIA				



## 110&LODE 'BAROCCO'

**porte a battente**  
hinged doors | portes à battant | puertas  
batiente Flügeltüren | распашная дверь

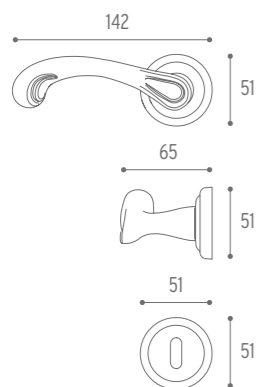

KEY PATENT\_TOILET\_YALE



## 110&LODE 'DECAPÈ'

**porte a battente**  
hinged doors | portes à battant | puertas  
batiente Flügeltüren | распашная дверь

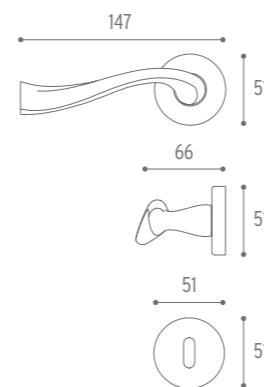

KEY PATENT\_TOILET\_YALE



## 110&LODE 'LISCIA'

**porte a battente**  
hinged doors | portes à battant | puertas  
batiente Flügeltüren | распашная дверь

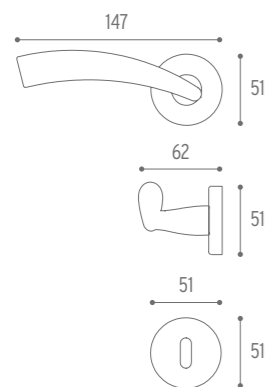

PATENT \_ TOILET \_ YALE

## AMBRA

**porte a battente**  
hinged doors | portes à battant | puertas  
batiente Flügeltüren | распашная дверь

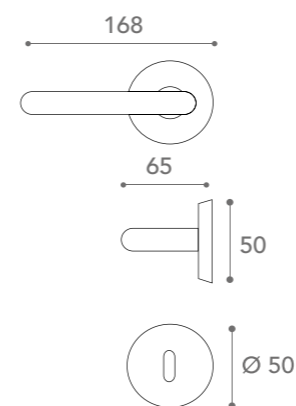

PATENT \_ TOILET \_ YALE

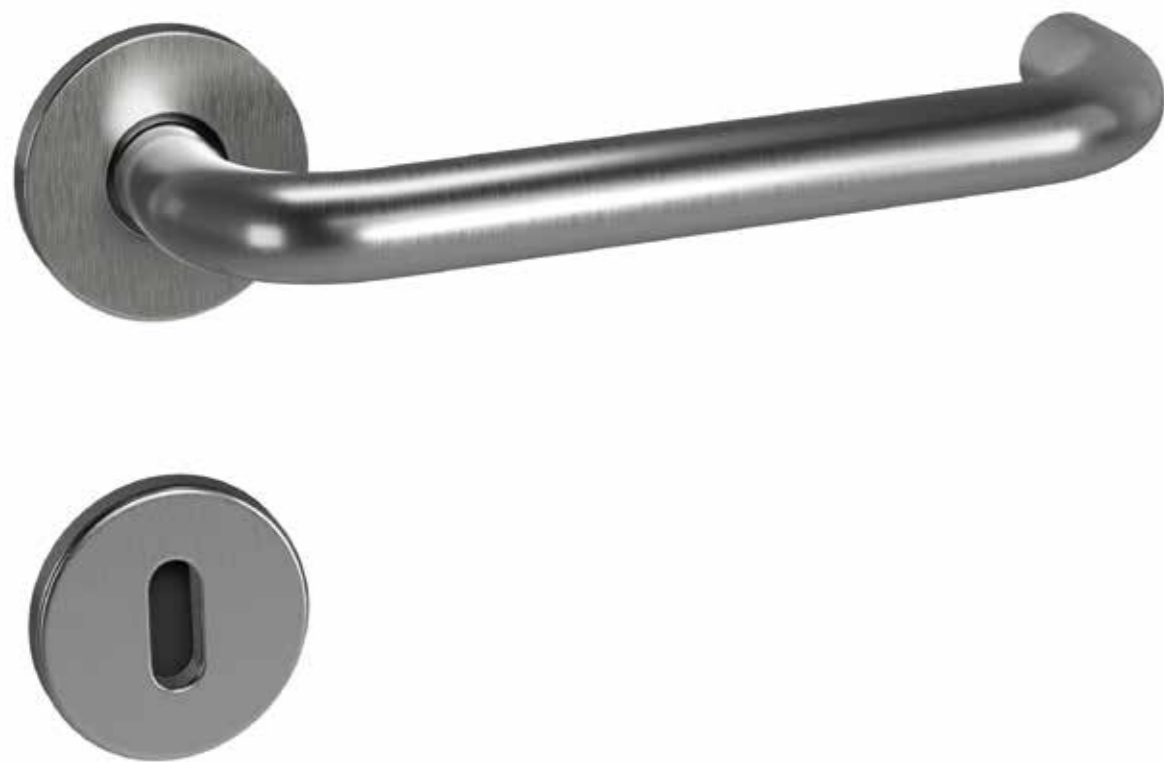

## AMBRA ALLUNGATA

**porte a battente**  
hinged doors | portes à battant | puertas  
batiente Flügeltüren | распашная дверь

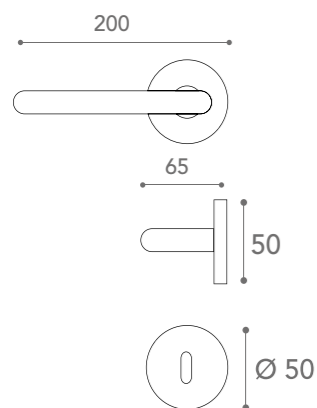

🔑 PATENT\_TOILET\_YALE



## AREA 51

**porte a battente**  
hinged doors | portes à battant | puertas  
batiente Flügeltüren | распашная дверь

**finestra a battente**  
hinged windows | fenêtre à battant | ventana batiente  
Flügelfenster | распашная окно

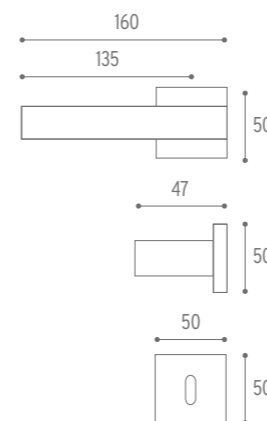

🔑 PATENT\_TOILET\_YALE

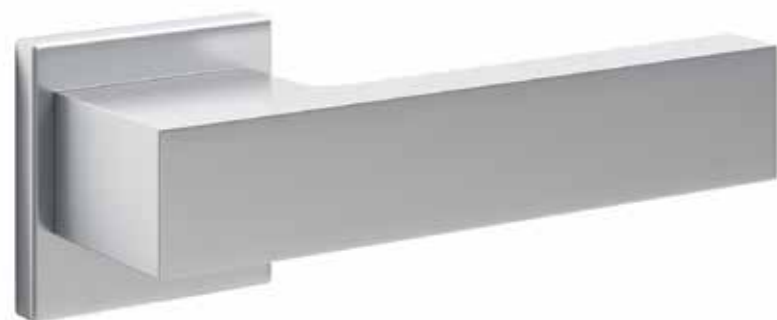

## AREA 52 ALLUMINIO

**porte a battente**  
hinged doors | portes à battant | puertas  
batiente Flügeltüren | распашная дверь

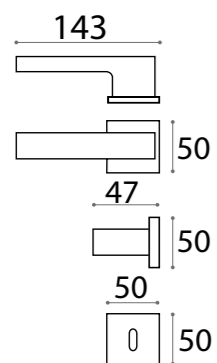

 PATENT \_ TOILET \_ YALE

## ATLANTA

**porte a battente**  
hinged doors | portes à battant | puertas  
batiente Flügeltüren | распашная дверь

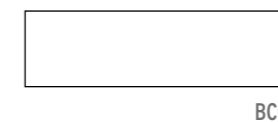
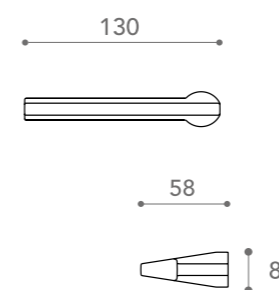

 PATENT \_ TOILET \_ YALE



## BASE

 **porte a battente**  
hinged doors | portes à battant | puertas  
batiente Flügeltüren | распашная дверь

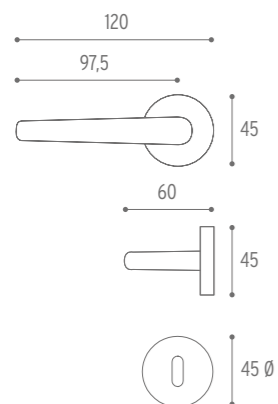

 PATENT\_TOILET\_YALE

## BLADE

 **porte a battente**  
hinged doors | portes à battant | puertas  
batiente Flügeltüren | распашная дверь

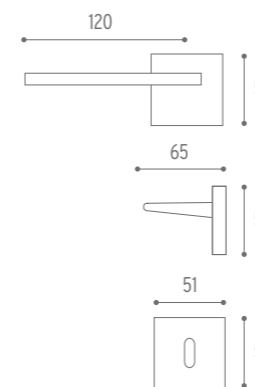

 PATENT\_TOILET\_YALE



## BOLT

 **porte a battente**  
hinged doors | portes à battant | puertas  
batiente Flügeltüren | распашная дверь

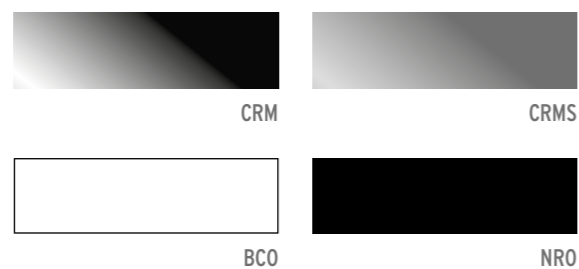
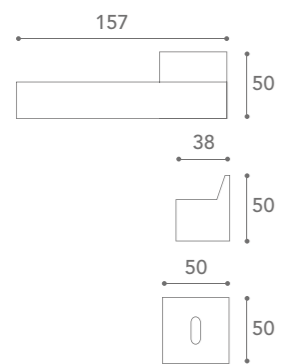

 PATENT\_TOILET\_YALE



## BOLT WOOD

 **porte a battente**  
hinged doors | portes à battant | puertas  
batiente Flügeltüren | распашная дверь

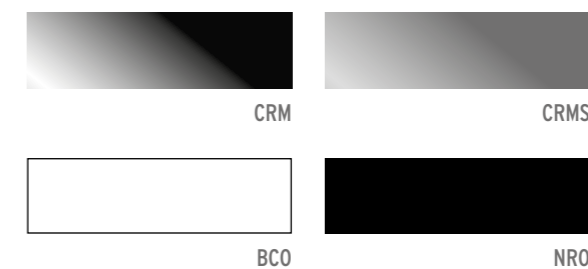
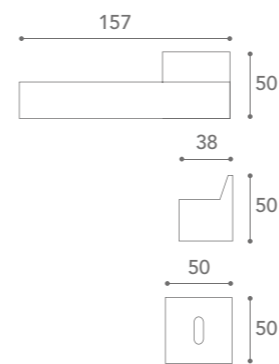

 PATENT\_TOILET\_YALE

**\*inserto disponibile in tutte le finiture Garofoli**  
\*insert available in all Garofoli finishes  
\*aplicación disponible en todos los acabados Garofoli  
\*Einsatz in allen Ausführungen von Garofoli erhältlich  
\*вставка доступна во всех вариантах отделки Garofoli



## CLASSICA 'NOSTRO MODELLO'

 **porte a battente**  
hinged doors | portes à battant | puertas  
batiente Flügeltüren | распашная дверь

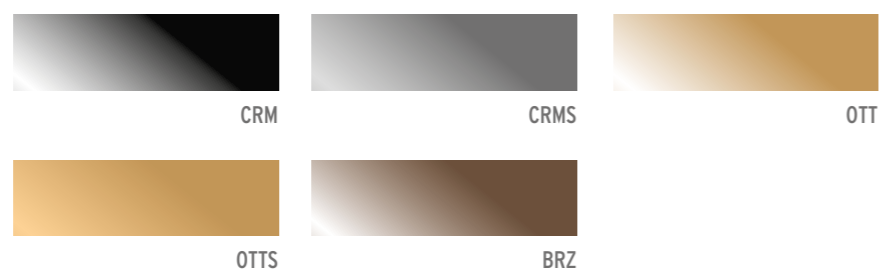
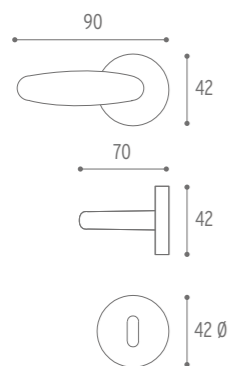

 PATENT\_TOILET\_YALE

## DUE

 **porte a battente**  
hinged doors | portes à battant | puertas  
batiente Flügeltüren | распашная дверь

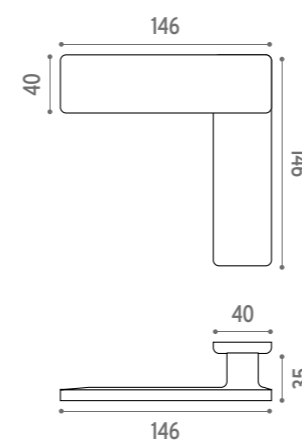

 PATENT\_TOILET\_YALE

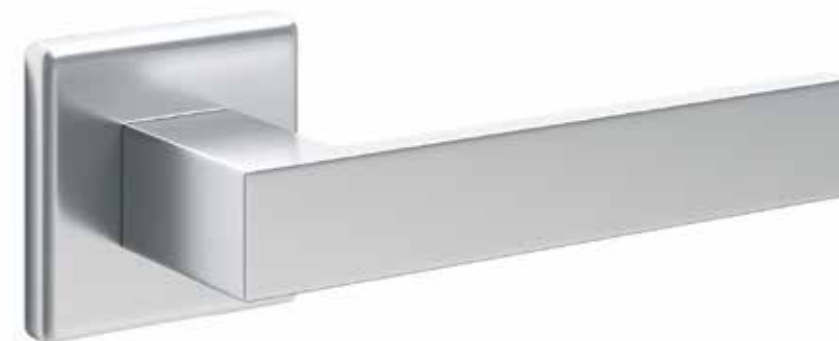

## DOLLY

 **porte a battente**  
hinged doors | portes à battant | puertas  
batiente Flügeltüren | распашная дверь

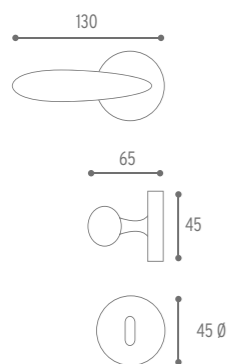

 PATENT\_TOILET\_YALE

## ECO ICE ALLUMINIO

 **porte a battente**  
hinged doors | portes à battant | puertas  
batiente Flügeltüren | распашная дверь

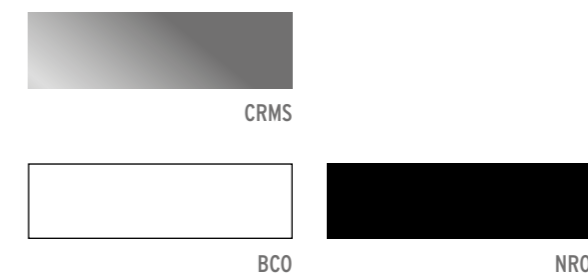

 PATENT\_TOILET\_YALE



## EIDOS

**porte a battente**  
hinged doors | portes à battant | puertas  
batiente Flügeltüren | распашная дверь

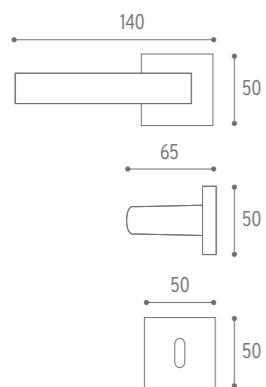

PATENT\_TOILET\_YALE

## FLOW

**porte a battente**  
hinged doors | portes à battant | puertas  
batiente Flügeltüren | распашная дверь

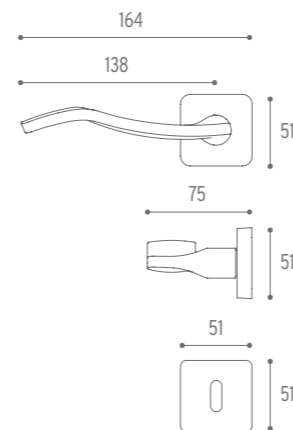

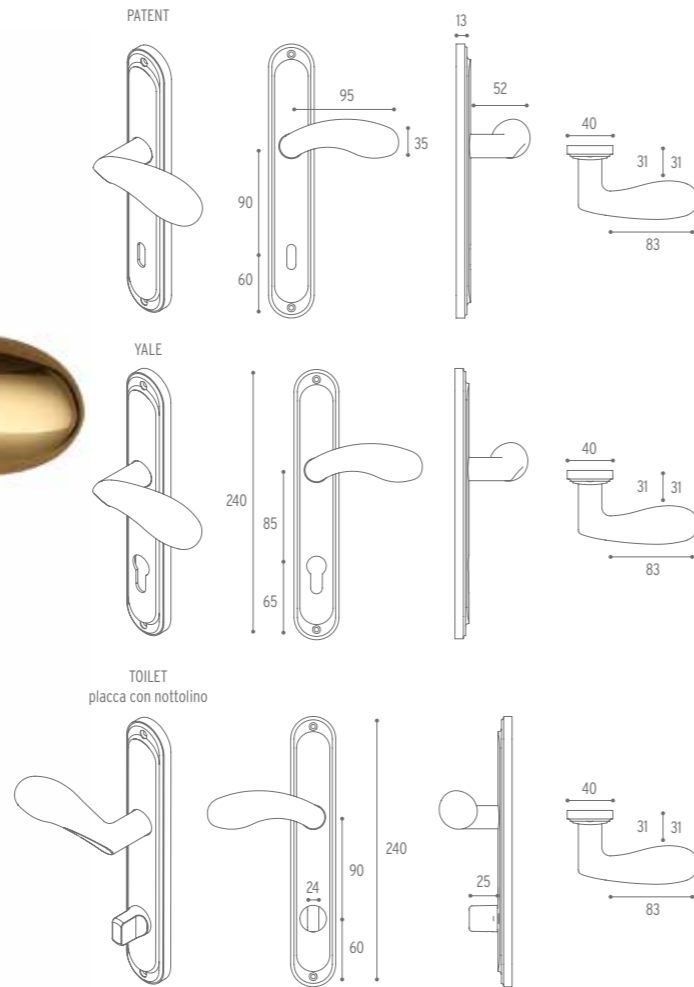

PATENT\_TOILET\_YALE



**il passo della placca vincola la serratura (la ferramenta deve avere lo stesso passo)** | the plate's pitch has an impact on the lock (the hardware must have the same pitch) | la serrure dépend du pas de la plaque (la quincaillerie doit avoir le même pas) | el paso de la placa vincula la cerradura (los herrajes deben tener la misma distancia) | Das Maß des Schilds legt die Größe des Schlosses fest (die Beschläge müssen das gleiche Maß haben) | шаг накладки определяет расположение замка (фурнитура должна иметь тот же шаг)



-  **porte a battente**  
hinged doors | portes à battant | puertas batiente Flügeltüren | распашная дверь
-  **finestra a battente**  
hinged windows | fenêtre à battant | ventana batiente Flügelfenster | распашная окно
-  **finestra scorrevole alzante**  
lifting sliding window | fenêtre levante coulissante ventana con deslizamiento en vertical | Hebe-Schiebefenster | раздвижное окно на всю высоту

## GOLF

-  **porte a battente**  
hinged doors | portes à battant | puertas batiente Flügeltüren | распашная дверь



**disponibile anche nella versione con rosette separate** | also available in the version with separate rosettes | disponible également en version avec rosaces séparées | disponible también en la versión con rosetas separadas | Auch erhältlich in der Version mit getrennten Rosetten | доступно также в исполнении с отдельными ручками на шайбе

 PATENT\_TOILET\_YALE

## ICE 2018

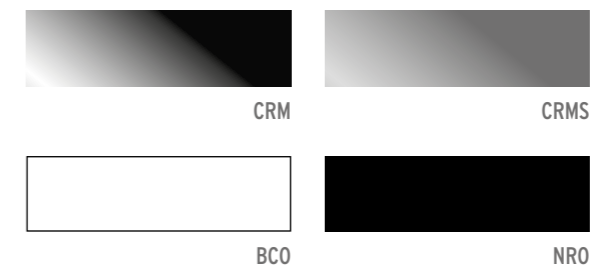
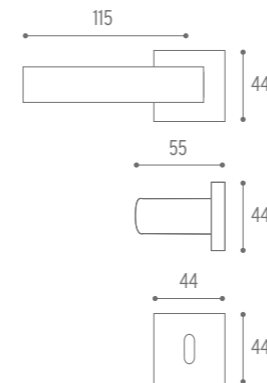

 PATENT\_TOILET\_YALE



## ICON

 **porte a battente**  
hinged doors | portes à battant | puertas  
batiente Flügeltüren | распашная дверь

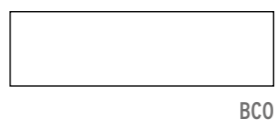
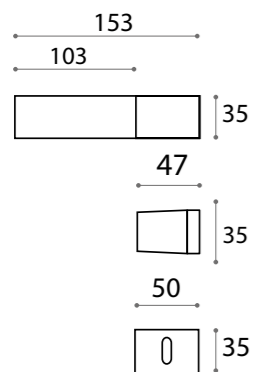

 PATENT \_ TOILET \_ YALE





## INFINITO

 **porte a battente**  
hinged doors | portes à battant | puertas  
batiente Flügeltüren | распашная дверь

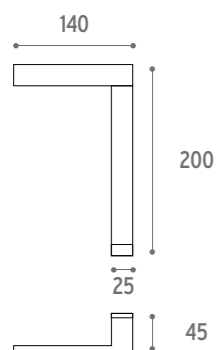

NRO



CRMS

 PATENT\_TOILET\_YALE





## INFINITO PLACCA LUNGA

 **porte a battente**  
hinged doors | portes à battant | puertas  
batiente Flügeltüren | распашная дверь

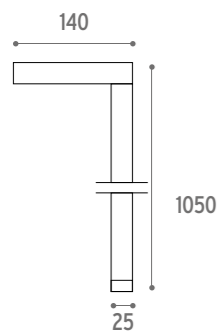

NRO



CRMS

 PATENT \_ TOILET \_ YALE

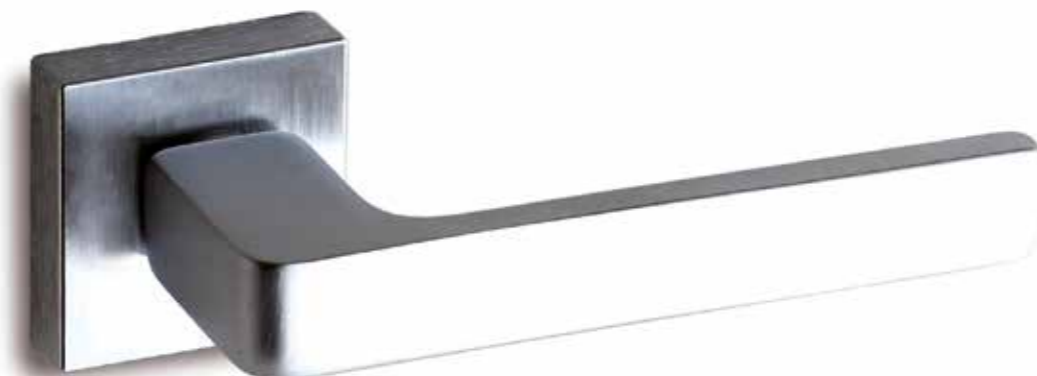

## KALÈ

**porte a battente**  
hinged doors | portes à battant | puertas  
batiente Flügeltüren | распашная дверь

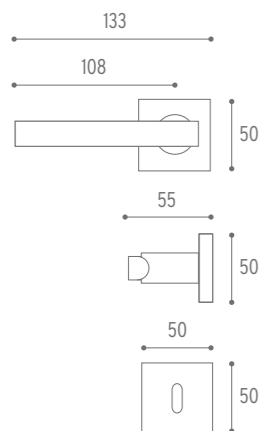

PATENT\_TOILET\_YALE

## LARIO

**porte a battente**  
hinged doors | portes à battant | puertas  
batiente Flügeltüren | распашная дверь

**finestra a battente**  
hinged windows | fenêtre à battant | ventana batiente  
Flügel Fenster | распашная окно

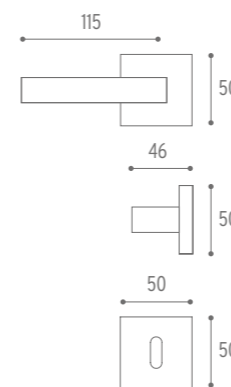

PATENT\_TOILET\_YALE



## LIFE

**porte a battente**  
hinged doors | portes à battant | puertas  
batiente Flügeltüren | распашная дверь

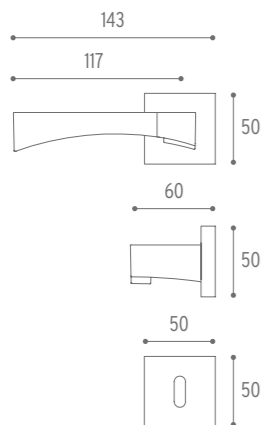

CRMS



OTTS

PATENT\_TOILET\_YALE

## LINK

**porte a battente**  
hinged doors | portes à battant | puertas  
batiente Flügeltüren | распашная дверь

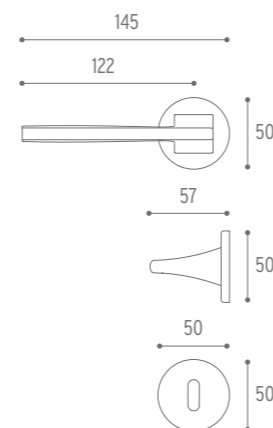



CRMS



OTTS

PATENT\_TOILET\_YALE



-  **porte a battente**  
hinged doors | portes à battant | puertas  
batiente Flügeltüren | распашная дверь
-  **finestra a battente**  
hinged windows | fenêtre à battant | ventana batiente  
Flügelfenster | распашная окно
-  **finestra scorrevole alzante**  
lifting sliding window | fenêtre levante coulissante  
ventana con deslizamiento en vertical | Hebe-  
Schiebefenster | раздвижное окно на всю высоту

## LUCE

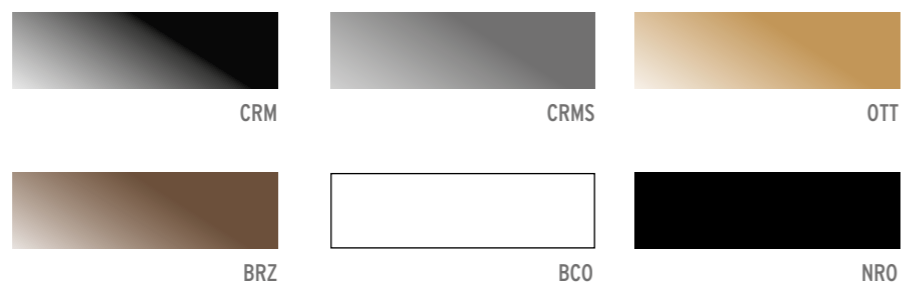
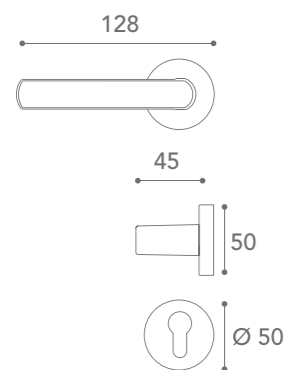

 PATENT\_TOILET\_YALE



## LUCE ORIZZONTALE

-  **porte a battente**  
hinged doors | portes à battant | puertas  
batiente Flügeltüren | распашная дверь

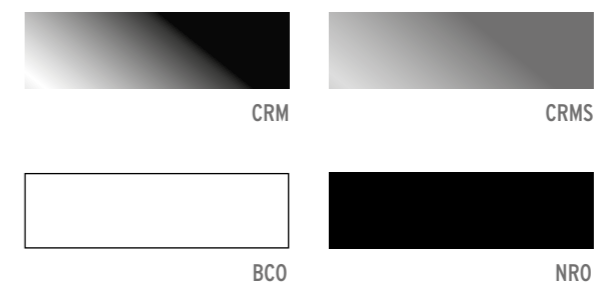
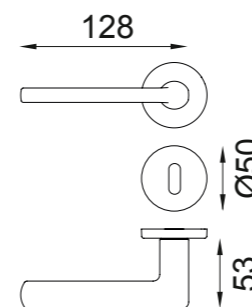

 PATENT\_TOILET\_YALE



con pulsante di chiusura incorporato nella maniglia  
with locking button built into the handle |  
avec bouton de fermeture incorporé dans la poignée |  
con botón de cierre incorporado en la manija |  
mit in der Türklinke eingebautem Schließknopf |  
с кнопкой закрытия, встроенной в рукоятку



## LUCIA

 **porte a battente**  
hinged doors | portes à battant | puertas  
batiente Flügeltüren | распашная дверь

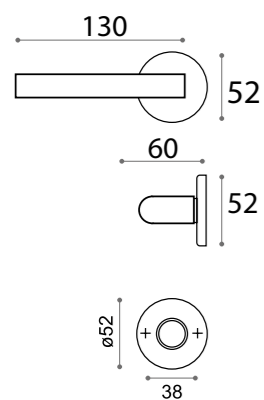

 PATENT\_TOILET\_YALE

## MILOX

 **porte a battente**  
hinged doors | portes à battant | puertas  
batiente Flügeltüren | распашная дверь

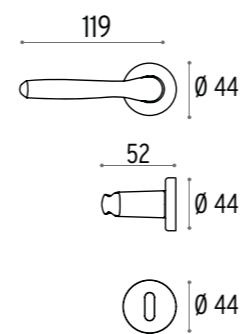



 PATENT\_TOILET\_YALE

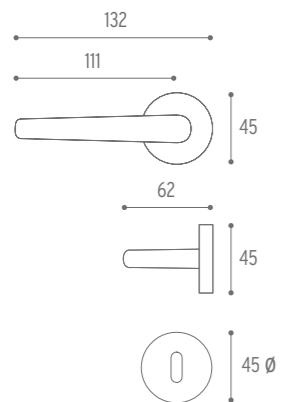

## MILENA

**porte a battente**  
hinged doors | portes à battant | puertas  
batiente Flügeltüren | распашная дверь



 PATENT\_TOILET\_YALE

## PLUS 2018

**porte a battente**  
hinged doors | portes à battant | puertas  
batiente Flügeltüren | распашная дверь

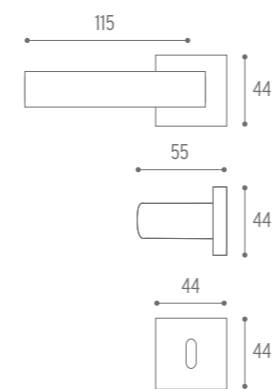

 PATENT\_TOILET\_YALE



## PURE

**porte a battente**  
hinged doors | portes à battant | puertas  
batiente Flügeltüren | распашная дверь

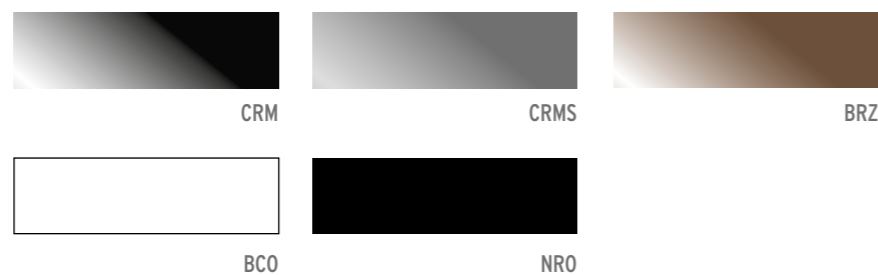
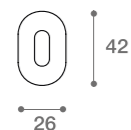

 PATENT\_TOILET\_YALE

## QUADRA

**porte a battente**  
hinged doors | portes à battant | puertas  
batiente Flügeltüren | распашная дверь

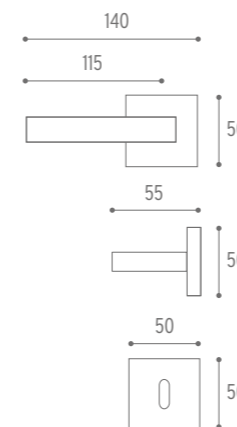

 PATENT\_TOILET\_YALE

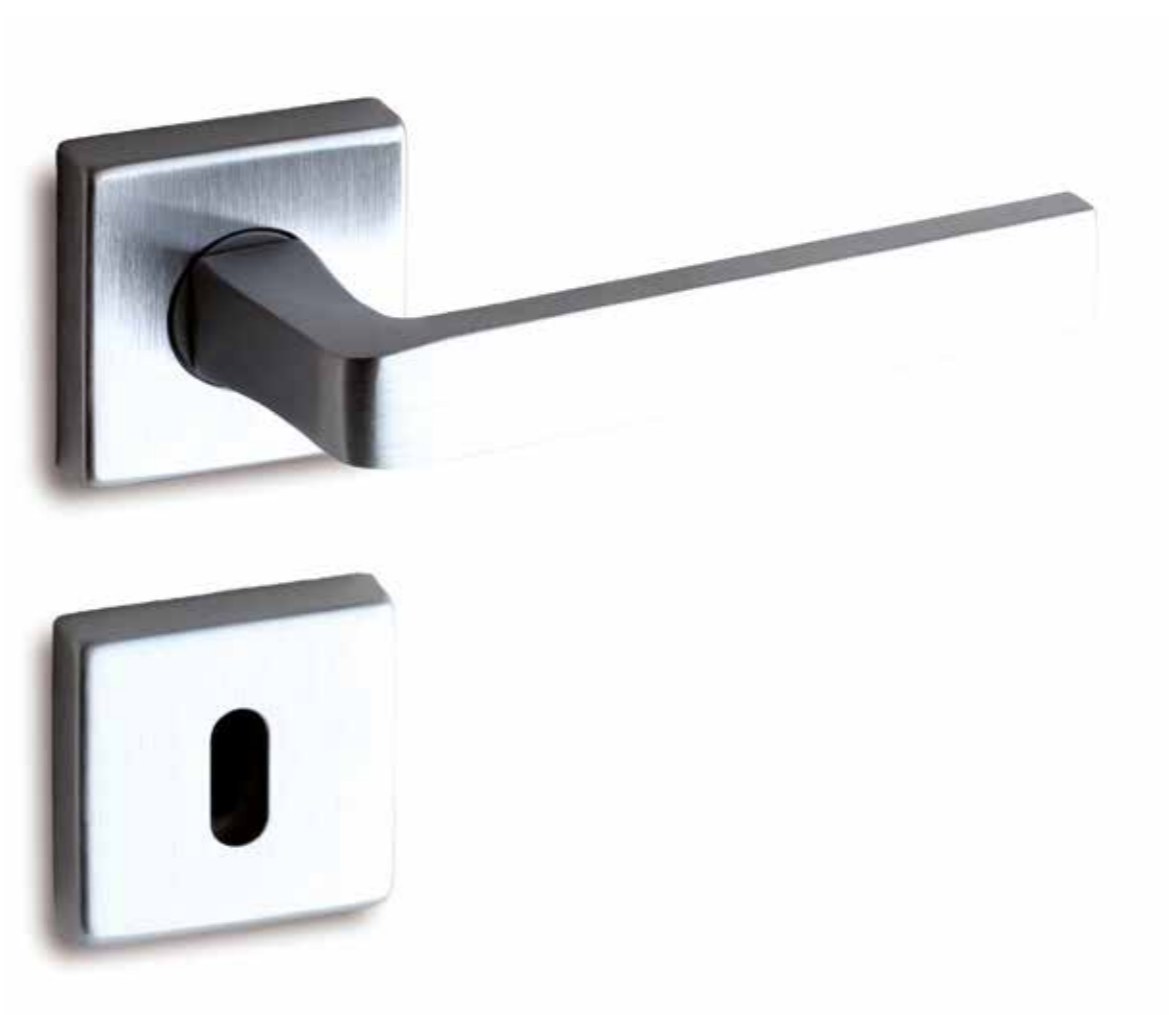

## SIRIO

**porte a battente**  
hinged doors | portes à battant | puertas  
batiente Flügeltüren | распашная дверь

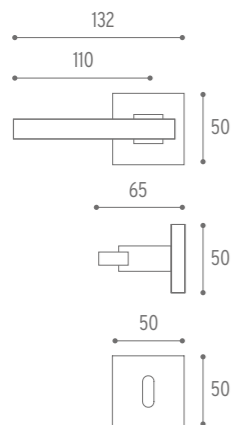

CRM/CRMS  
BICOLOR

INOX

rosetta a stelo cromo lucido/impugnatura cromo satinato | knob with stem in polished chrome/satin chrome grip |  
rosace et tige chrome brillant/poignée chrome satiné | roseta con tallo cromo brillante/empuñadura cromo satinado  
| Rosette mit Stiel Chrom poliert/Griff Chrom satiniert | ручка стержневая на шайбе с глянцевой хромированной  
отделкой/сатинированная хромированная ручка

PATENT\_TOILET\_YALE

## SMART

**porte a battente**  
hinged doors | portes à battant | puertas  
batiente Flügeltüren | распашная дверь

**finestra a battente**  
hinged windows | fenêtrre à battant | ventana batiente  
Flügelfenster | распашная окно

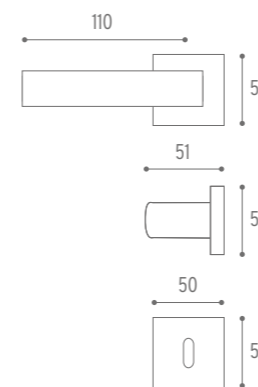

CRM

CRMS

PATENT\_TOILET\_YALE



## SPRINT

**porte a battente**  
hinged doors | portes à battant | puertas  
batiente Flügeltüren | распашная дверь

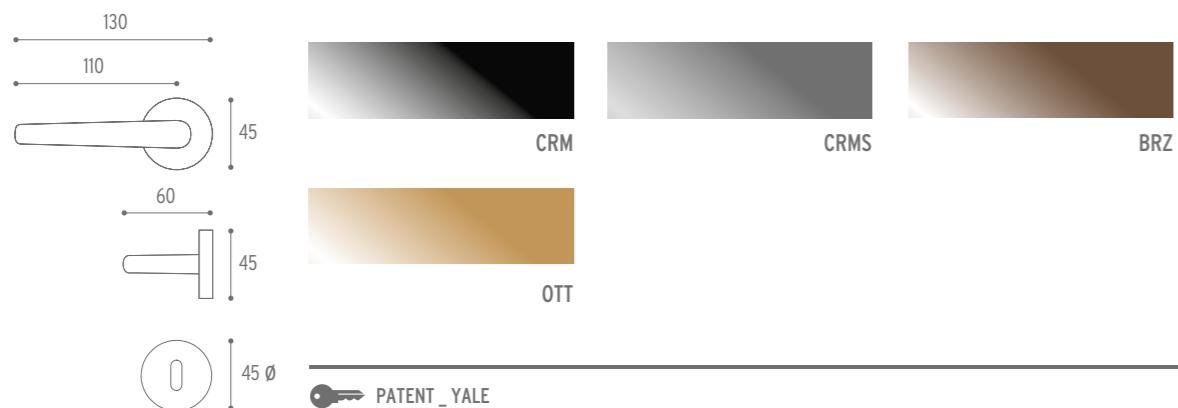

## SQUADRA

**porte a battente**  
hinged doors | portes à battant | puertas  
batiente Flügeltüren | распашная дверь

**finestra a battente**  
hinged windows | fenêtre à battant | ventana batiente  
Flügelfenster | распашная окно

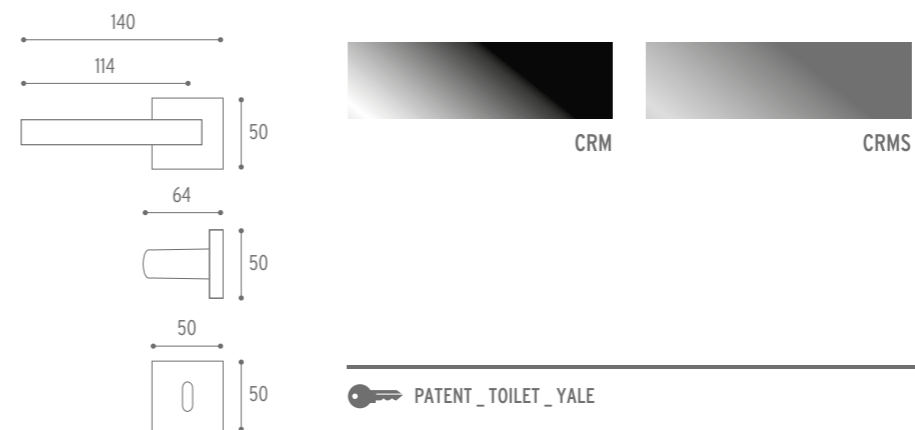



1\_MANIGLIE | HANDLES | POIGNÉES | MANILLAS | GRIFFE | РУЧКИ



## TIMELESS

 **porte a battente**  
hinged doors | portes à battant | puertas  
batiente Flügeltüren | распашная дверь

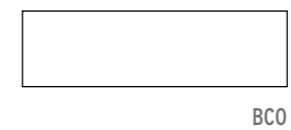
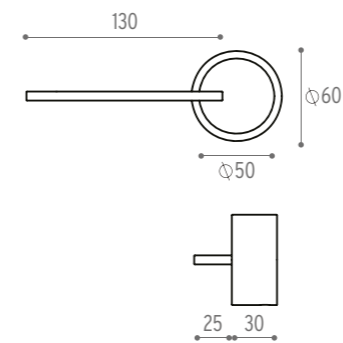



## TUKE GLASS

**porte a battente**  
hinged doors | portes à battant | puertas  
batiente Flügeltüren | распашная дверь

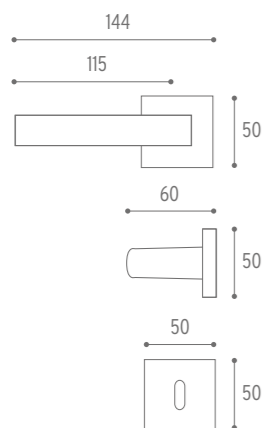

PATENT\_TOILET\_YALE

## TUKE

**porte a battente**  
hinged doors | portes à battant | puertas  
batiente Flügeltüren | распашная дверь

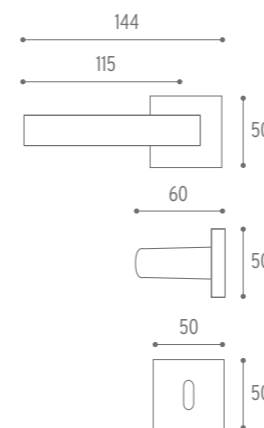

PATENT\_TOILET\_YALE



## UNO

 **porte a battente**  
hinged doors | portes à battant | puertas  
batiente Flügeltüren | распашная дверь

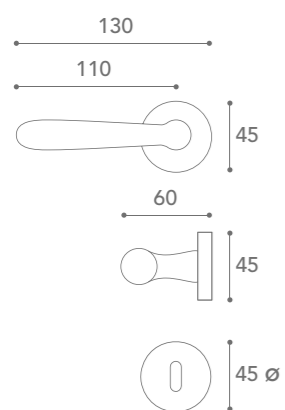

 PATENT\_TOILET\_YALE



## WING

 **porte a battente**  
hinged doors | portes à battant | puertas  
batiente Flügeltüren | распашная дверь

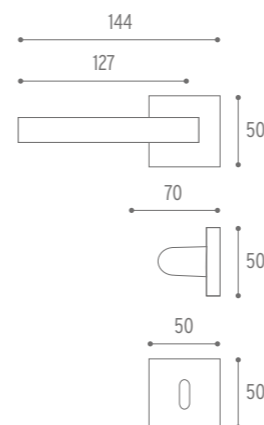

 PATENT\_TOILET\_YALE



\*inserto disponibile in tutte le finiture Garofoli  
 \*insert available in all Garofoli finishes  
 \*aplicación disponible en todos los acabados Garofoli  
 \*Einsatz in allen Ausführungen von Garofoli erhältlich  
 \*вставка доступна во всех вариантах отделки Garofoli

## WINNER WOOD

**porte a battente**  
 hinged doors | portes à battant | puertas  
 batiente Flügeltüren | распашная дверь

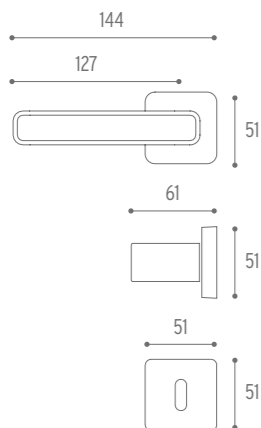

con inserto in legno a scelta nelle essenze 'porte Garofoli' da specificare in fase di ordine | with wooden insert available in the "Garofoli doors" wood finishes to be specified when drafting the order | avec insert en bois au choix dans les mêmes essences que les « portes Garofoli », à spécifier lors de la commande | con aplicación de madera a elección entre los colores "puertas Garofoli" (especificar en el pedido) | Mit Holzeinsatz nach Wahl in den Holzarten der „Garofoli-Türen“ bei der Bestellung anzugeben | с деревянной вставкой на выбор из массива 'двери Garofoli', который указывается на этапе размещения заказа

PATENT\_TOILET\_YALE



XOSIA per serratura Tao  
 (con logo Gidea)

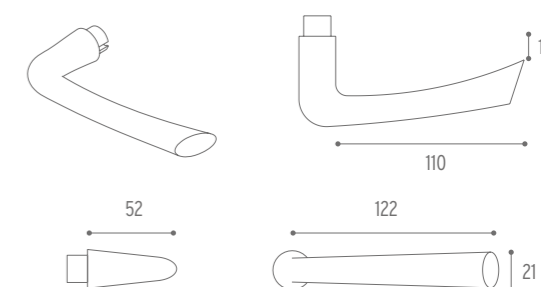

## XOSIA

**porte a battente**  
 hinged doors | portes à battant | puertas  
 batiente Flügeltüren | распашная дверь

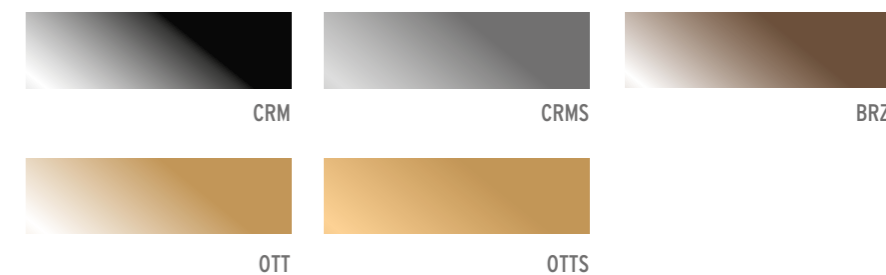
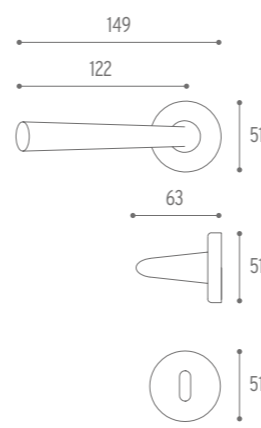

PATENT\_TOILET\_YALE

## ALCUNI DEI NOTTOLINI DISPONIBILI



AMBRA



AREA 51



BASE / SPRINT



BLADE



SPLENDIA



XOSIA



110 E LODE LISCIA



BOLT



ICE



LARIO



LUCE



PURE



SMART



SQUADRA





TUBE



## PLAYA

 **porte a battente** hinged doors |  
portes à battant | puertas batiente  
Flügeltüren | распашная дверь

 **porte scorrevoli** sliding doors | portes  
coulissantes | puertas correderas  
Schiebetüren | раздвижные двери

 **armadi/contentori** wardrobes/  
containers armoires/rangements |  
armarios/módulos  
Schränke/Behälter | шкафы/ящики



TIPOLOGIA DI KIT | TYPE OF KIT | TYPE DE KIT | TIPO DE KIT | TYPOLOGIE DES KIT | ТИП КОМПЛЕКТА

**STANDARD (vaschetta con nottolino lato a tirare + vaschetta lato a spingere)** | standard (recessed handle with pawl on pull side + recessed handle on push side) | standard (cuvette avec loquet côté à tirer + cuvette côté à pousser) | estándar (uñero con botón mariposa lado de tracción + uñero lado de empuje) | Standard (Schalengriff mit Drehriegel auf zu ziehender Seite + Schalengriff auf Stoßseite) | стандартного типа (утопленная ручка со щеколдой на стороне "на себя" + утопленная ручка на стороне "от себя")

**porte a battente** hinged doors | portes à battant | puertas batiente Flügeltüren | распашная дверь

stilia, stilia con profili in alluminio, lammy poema, smart, luxopoema, filomuro, grain, bisystem, filomuro, gabilia, gdesigner, miraquadra, poema, quaranta.

**porte scorrevoli** sliding doors | portes coulissantes | puertas correderas Schiebetüren | раздвижные двери

stilia, stilia con profili in alluminio, lammy poema, smart, luxopoema, filomuro, xosia, genia, xonda, grain, arca, bisystem, filomuro, gabilia, gdesigner, mirabilia, miraquadra, poema, quaranta, sublimia.

**YALE (vaschetta con nottolino lato a tirare + vaschetta con chiave lato a spingere)** | Yale (recessed handle with pawl on pull side + recessed handle with key on push side) | yale (cuvette avec loquet côté à tirer + cuvette avec clé côté à pousser) | yale (uñero con botón mariposa lado de tracción + uñero con llave lado de empuje) | Yale (Schalengriff mit Drehriegel auf zu ziehender Seite + Schalengriff mit Schlüssel auf Stoßseite) | типа yale (утопленная ручка со щеколдой на стороне "на себя" + утопленная ручка с ключом на стороне "от себя")

**porte a battente** hinged doors | portes à battant | puertas batiente Flügeltüren | распашная дверь

stilia, stilia con profili in alluminio, lammy poema, smart, luxopoema, miria, filomuro, grain, bisystem, filomuro, gabilia, gdesigner, miraquadra, poema, quaranta.

**porte scorrevoli** sliding doors | portes coulissantes | puertas correderas Schiebetüren | раздвижные двери

stilia, stilia con profili in alluminio, lammy poema, smart, luxopoema, miria, filomuro, xosia, genia, xonda, grain, arca, bisystem, filomuro, gabilia, gdesigner, mirabilia, miraquadra, poema, quaranta, sublimia.

**SOLO VASCHETTA (vaschetta lato a tirare + vaschetta lato a spingere)** | recessed handle only (recessed handle on pull side + recessed handle on push side) | cuvette uniquement (cuvette côté à tirer + cuvette côté à pousser) | sólo uñero (uñero del lado de tracción + uñero del lado de empuje) | nur Schalengriff (Schalengriff auf zu ziehender Seite + Schalengriff auf Stoßseite) | только утопленная ручка (утопленная ручка на стороне "на себя" + утопленная ручка на стороне "от себя")

**porte scorrevoli** sliding doors | portes coulissantes | puertas correderas Schiebetüren | раздвижные двери

stilia, stilia con profili in alluminio, lammy poema, smart, luxopoema, miria, filomuro, xosia, genia, xonda, grain, arca, bisystem, filomuro, gabilia, gdesigner, io, mirabilia, miraquadra, pangea, poema, quaranta, sublimia.



**maniglia a vaschetta playa** | Playa recessed handle | Poignée encastrée Playa | Uñero Playa | Griffschale Playa | встроенная ручка Playa

**serratura/maniglia a vaschetta Playa con chiave lato esterno e pulsante lato interno** | Lock / Playa recessed handle with key on outer side and button on inner side | Serrure/poignée encastrée Playa avec clé côté extérieur et bouton côté intérieur | Cerradura / Uñero Playa con llave lado externo y botón lado interno | Schloss / Griffschale Playa mit Schlüssel außen und Knopf innen



YALE

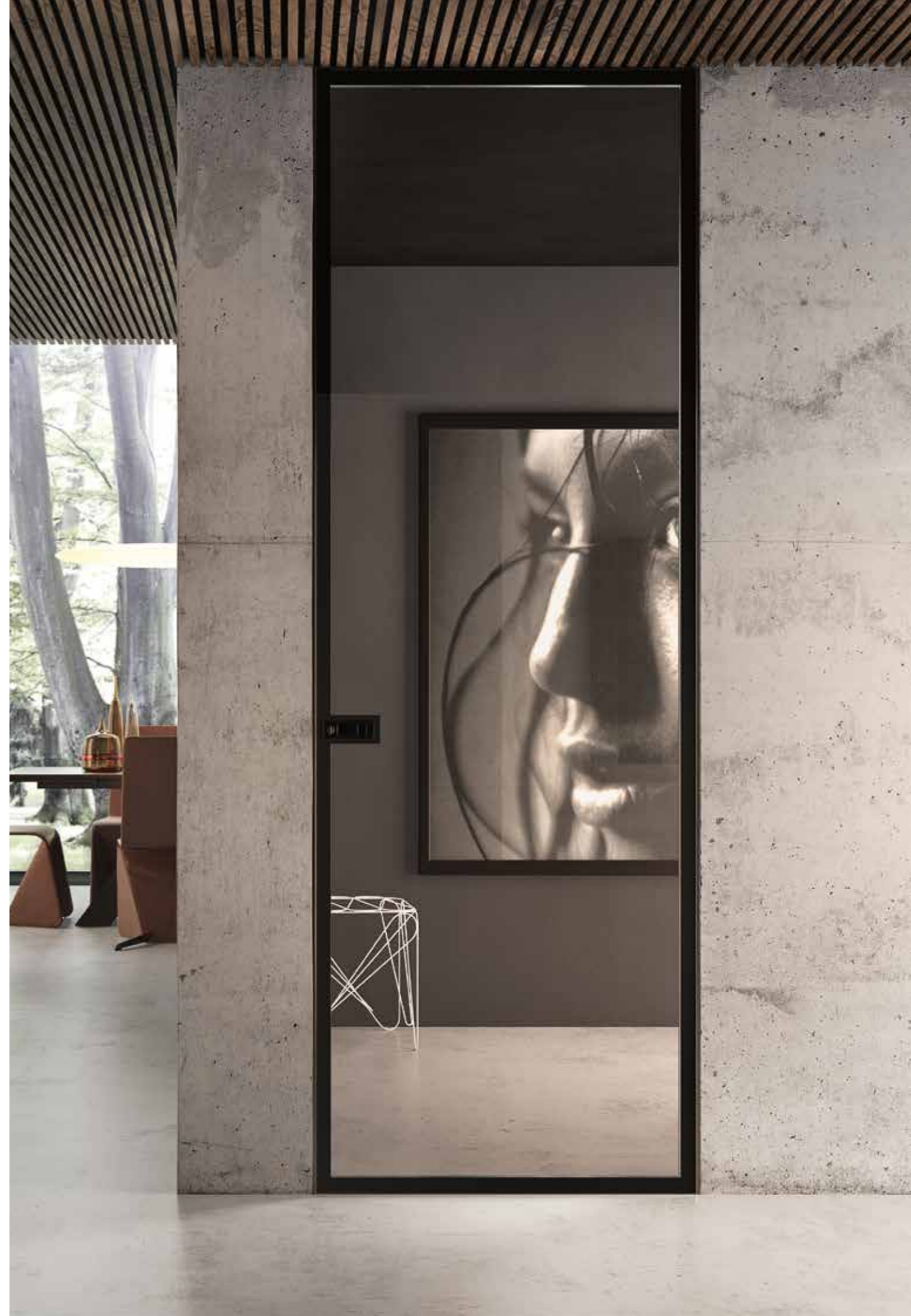

## FLUÒ

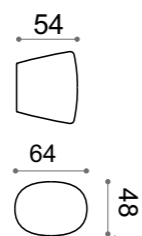

CRM CRMS  
**Disponibile solo in kit** | Available only in kits |  
 Disponible uniquement en kit | Disponible solo en kit |  
 Nur im Satz erhältlich | Доступно только в комплекте



## PEGASO

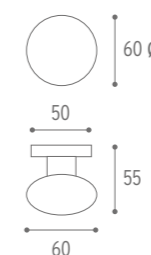

CRM CRMS  
**Disponibile solo in kit** | Available only in kits |  
 Disponible uniquement en kit | Disponible solo en kit |  
 Nur im Satz erhältlich | Доступно только в комплекте

## FRAME

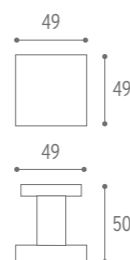

CRM CRMS  
**NOTA: disponibile anche in versione girevole, da utilizzare come una maniglia** | NOTE: Also available in a swivel version, to be used as a handle | RENARQUE: disponible uniquement en version tournante, à utiliser comme poignée | NOTA: disponible también en versión giratoria, para su uso como manilla | HINWEIS: auch in der drehbaren Ausführung zur Verwendung als Türklinke erhältlich | ПРИМЕЧАНИЕ: доступна также вращающаяся версия для использования в качестве ручки



## RONDÒ

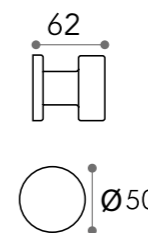

INOX  
**Disponibile solo in kit** | Available only in kits |  
 Disponible uniquement en kit | Disponible solo en kit |  
 Nur im Satz erhältlich | Доступно только в комплекте

## MILENA FISSO

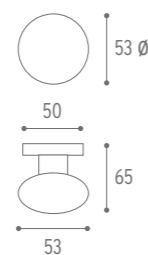

CRM CRMS OTT  
**NOTA: disponibile anche in versione girevole, da utilizzare come una maniglia** | NOTE: Also available in a swivel version, to be used as a handle | RENARQUE: disponible uniquement en version tournante, à utiliser comme poignée | NOTA: disponible también en versión giratoria, para su uso como manilla | HINWEIS: auch in der drehbaren Ausführung zur Verwendung als Türklinke erhältlich | ПРИМЕЧАНИЕ: доступна также вращающаяся версия для использования в качестве ручки



## SQUADRA

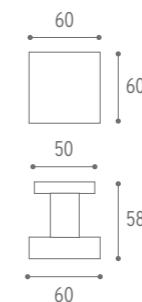

CRM CRMS  
 BCO NRO  
**Disponibile solo in kit** | Available only in kits |  
 Disponible uniquement en kit | Disponible solo en kit |  
 Nur im Satz erhältlich | Доступно только в комплекте



## SQUADRA DECENTRATO

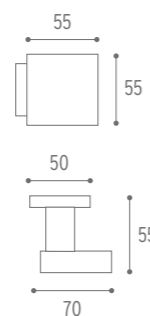

**NOTA: disponibile anche in versione girevole, da utilizzare come una maniglia** | NOTE: Also available in a swivel version, to be used as a handle | **REMARQUE: disponible uniquement en version tournante, à utiliser comme poignée** | **NOTA: disponible también en versión giratoria, para su uso como manilla** | **HINWEIS: auch in der drehbaren Ausführung zur Verwendung als Türklinke erhältlich** | **ПРИМЕЧАНИЕ: доступна также вращающаяся версия для использования в качестве ручки**



## WING

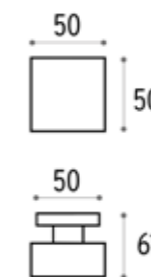

## SVEZIA

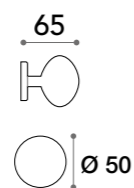

**Disponibile solo in kit** | Available only in kits | **Disponible uniquement en kit** | **Disponibile solo en kit** | **Nur im Satz erhältlich** | **Доступно только в комплекте**

## TONDO

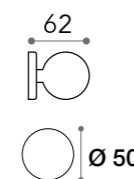

**Disponibile solo in kit** | Available only in kits | **Disponible uniquement en kit** | **Disponibile solo en kit** | **Nur im Satz erhältlich** | **Доступно только в комплекте**

**i pomoli sono disponibili sia in versione fissa che girevole ad uso maniglia, se non diversamente specificato la fornitura sarà con pomolo fisso** | the knobs are available in both the fixed and rotating version functioning as a handle; unless otherwise specified, the fixed knob will be supplied | **les boutons sont disponibles à la fois en version fixe et en version tournante à usage de poignée. Sauf spécification contraire, c'est le bouton fixe qui sera fourni** | **los pomos están disponibles en versión fija o giratoria tipo manilla; si no se especifica otra cosa, se suministra el pomo fijo** | **Die Knäufe stehen sowohl in fester als auch drehbarer Version, verwendbar als Griff, zur Verfügung; bei Fehlen von anderweitigen Angaben wird der feste Knäuf geliefert** | **круглые ручки доступны как в фиксированном исполнении, так и в поворотном в качестве обычной ручки; если иное не оговорено, поставка будет произведена с фиксированной круглой ручкой**



## POMOLI TONDI GAROFOLI

**porte a battente** | hinged doors | portes à battant |  
puertas batiente Flügeltüren | распашная дверь

**porte ventola** | swinging doors | portes en éventail |  
puertas de vaivén | Pendeltüren | вращающиеся двери

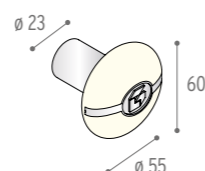

Per l'inserimento del pomo sulla porta tipologia battente occorre necessariamente montare sull'anta una serratura a scrocco, o elemento simile, per garantire il contatto della guarnizione tra telaio-anta. Soluzione non disponibile in caso di tipologie battente con ante lisce tamburate (In caso di dubbi consultare il manuale tecnico Gidea o richiedere la fattibilità agli uffici tecnici Garofoli o Gidea). | In order to insert the knob on the hinged door version, it is necessary to mount a latch lock - or similar accessory - on the door leaf, to ensure contact with the seal between the frame-door leaf. Solution not available in case of hinged door versions with flat hollow-core door leaves (in case of doubts, consult the Gidea technical manual or request feasibility from the Garofoli or Gidea technical departments). | Pour l'insertion du bouton sur la porte de type à battant, il faut obligatoirement installer sur la porte une serrure à loquet, ou un élément similaire, afin de garantir le contact entre le joint situé entre le cadre et la porte. Solution non disponible en cas de types à battant avec vantaux lisses à structure alvéolaire (en cas de doutes, consulter le manuel technique Gidea ou se renseigner sur la faisabilité auprès des bureaux techniques Garofoli ou Gidea). | Para colocar el pomo en la puerta de tipo batiente es necesario poner en la hoja una cerradura de golpe o similar, para garantizar el contacto de la junta entre el marco y la hoja. Solución no disponible en caso de puertas batientes con hojas lisas contrachapadas (en caso de dudas, consultar el manual técnico Gidea o informarse sobre la factibilidad en las oficinas técnicas Garofoli o Gidea). | Zum Einfügen des Knaufs an Türen wie Flügeltüren muss am Türflügel ein Fallenschloss oder ein ähnliches Teil montiert werden, um den Kontakt der Dichtung zwischen Zarge und Flügel zu gewährleisten. Diese Lösung ist bei Flügeltüren mit glatten Furnierholztüren nicht erhältlich (konsultieren Sie bei Zweifeln das technische Gidea-Handbuch oder fragen Sie bei den technischen Garofoli- oder Gidea-Büros die Machbarkeit nach). | Для установки круглой ручки на распашные гладкие двери необходимо обязательно врезать в дверь пружинную защелку или подобное приспособление, гарантирующее контакт уплотнения между рамой и створкой. Решение недоступно в случае распашных гладких дверей с мелкопустотным заполнением (при возникновении сомнений обратиться к техническому руководству Gidea или в технические отделы Garofoli или Gidea).

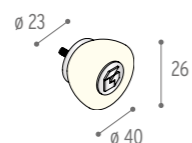

**porte scorrevoli** sliding doors | portes  
coulissantes | puertas correderas  
Schiebetüren | раздвижные двери



installabili solo su porta tutto vetro 1TV | installable only on 1TV Tuttovetro door | peuvent être installées uniquement sur les portes Tuttovetro 1TV | instalables sólo en puerta Tuttovetro 1TV | Nur montierbar auf Ganzglastür 1TV | может устанавливаться только на полностью стеклянной двери 1TV



4\_KIT POMOLO+MANIGLIA | KNOB+HANDLE KIT | KIT BOUTON+POIGNÉE | KIT POMO+MANILLA  
| KNAUF+GRIFF | КОМПЛЕКТ КРУГЛАЯ РУЧКА+РУЧКА



## GOLF+PEGASO

Kit Hotel Top



YALE

disponibile anche nella versione con rosette separate | also available in the version with separate rosettes | disponible également en version avec rosaces séparées | disponible también en la versión con rosetas separadas | Auch erhältlich in der Version mit getrennten Rosetten | доступно также в исполнении с отдельными ручками на шайбе



## MILENA

Kit Hotel Milena



YALE



## SQUADRA DECENTRATO

Kit Hotel Squadra Decentrato



YALE



## QUATTRO + ICE 2018

Kit Hotel Ice



YALE

i pomoli sono disponibili sia in versione fissa che girevole ad uso maniglia, se non diversamente specificato la fornitura sarà con pomolo fisso  
| the knobs are available in both the fixed and rotating version functioning as a handle; unless otherwise specified, the fixed knob will be supplied  
| les boutons sont disponibles à la fois en version fixe et en version tournante à usage de poignée. Sauf spécification contraire, c'est le bouton fixe qui sera fourni  
| los pomos están disponibles en versión fija o giratoria tipo manilla; si no se especifica otra cosa, se suministra el pomo fijo | Die Knäufe stehen sowohl in fester als auch drehbarer Version, verwendbar als Griff, zur Verfügung; bei Fehlen von anderweitigen Angaben wird der feste Knauf geliefert | круглые ручки доступны как в фиксированном исполнении, так и в поворотном в качестве обычной ручки; если иное не оговорено, поставка будет произведена с фиксированной круглой ручкой

4\_KIT POMOLO+MANIGLIA | KNOB+HANDLE KIT | KIT BOUTON+POIGNÉE | KIT POMO+MANILLA  
| KNAUF+GRIFF | КОМПЛЕКТ КРУГЛАЯ РУЧКА+РУЧКА



## FLUÒ + LUCE

Kit Hotel Luce



YALE



## SVEZIA + DOLLY

Kit Hotel Dolly



YALE



## TONDO + AMBRA

Kit Hotel Ambra



YALE



## RONDÒ + AMBRA

Kit Hotel Ambra



YALE

i pomoli sono disponibili sia in versione fissa che girevole ad uso maniglia, se non diversamente specificato la fornitura sarà con pomolo fisso  
| the knobs are available in both the fixed and rotating version functioning as a handle; unless otherwise specified, the fixed knob will be supplied  
| les boutons sont disponibles à la fois en version fixe et en version tournante à usage de poignée. Sauf spécification contraire, c'est le bouton fixe qui sera fourni  
| los pomos están disponibles en versión fija o giratoria tipo manilla; si no se especifica otra cosa, se suministra el pomo fijo | Die Knäufe stehen sowohl in fester als auch drehbarer Version, verwendbar als Griff, zur Verfügung; bei Fehlen von anderweitigen Angaben wird der feste Knauf geliefert | круглые ручки доступны как в фиксированном исполнении, так и в поворотном в качестве обычной ручки; если иное не оговорено, поставка будет произведена с фиксированной круглой ручкой



## SQUADRA DEC. + SMART Kit Hotel Smart



## WING Kit Hotel Wing



## FRAME + NEW YORK Kit Hotel New York



**i pomoli sono disponibili sia in versione fissa che girevole ad uso maniglia, se non diversamente specificato la forniture sarà con pomolo fisso**

| the knobs are available in both the fixed and rotating version functioning as a handle; unless otherwise specified, the fixed knob will be supplied

| les boutons sont disponibles à la fois en version fixe et en version tournante à usage de poignée. Sauf spécification contraire, c'est le bouton fixe qui sera fourni

| los pomos están disponibles en versión fija o giratoria tipo manilla; si no se especifica otra cosa, se suministra el pomo fijo | Die Knäufe stehen sowohl in fester

als auch drehbarer Version, verwendbar als Griff, zur Verfügung; bei Fehlen von anderweitigen Angaben wird der feste Knauf geliefert | круглые ручки доступны

как в фиксированном исполнении, так и в поворотном в качестве обычной ручки; если иное не оговорено, поставка будет произведена с фиксированной

круглой ручкой

## MANIGLIONE 25/55/90 cm



porte a battente hinged doors |  
portes à battant | puertas batiente  
Flügeltüren | распашная дверь



porte scorrevoli sliding doors | portes  
coulissantes | puertas correderas  
Schiebetüren | раздвижные двери



armadi wardrobes | armoires |  
armarios | Schränke | шкафы

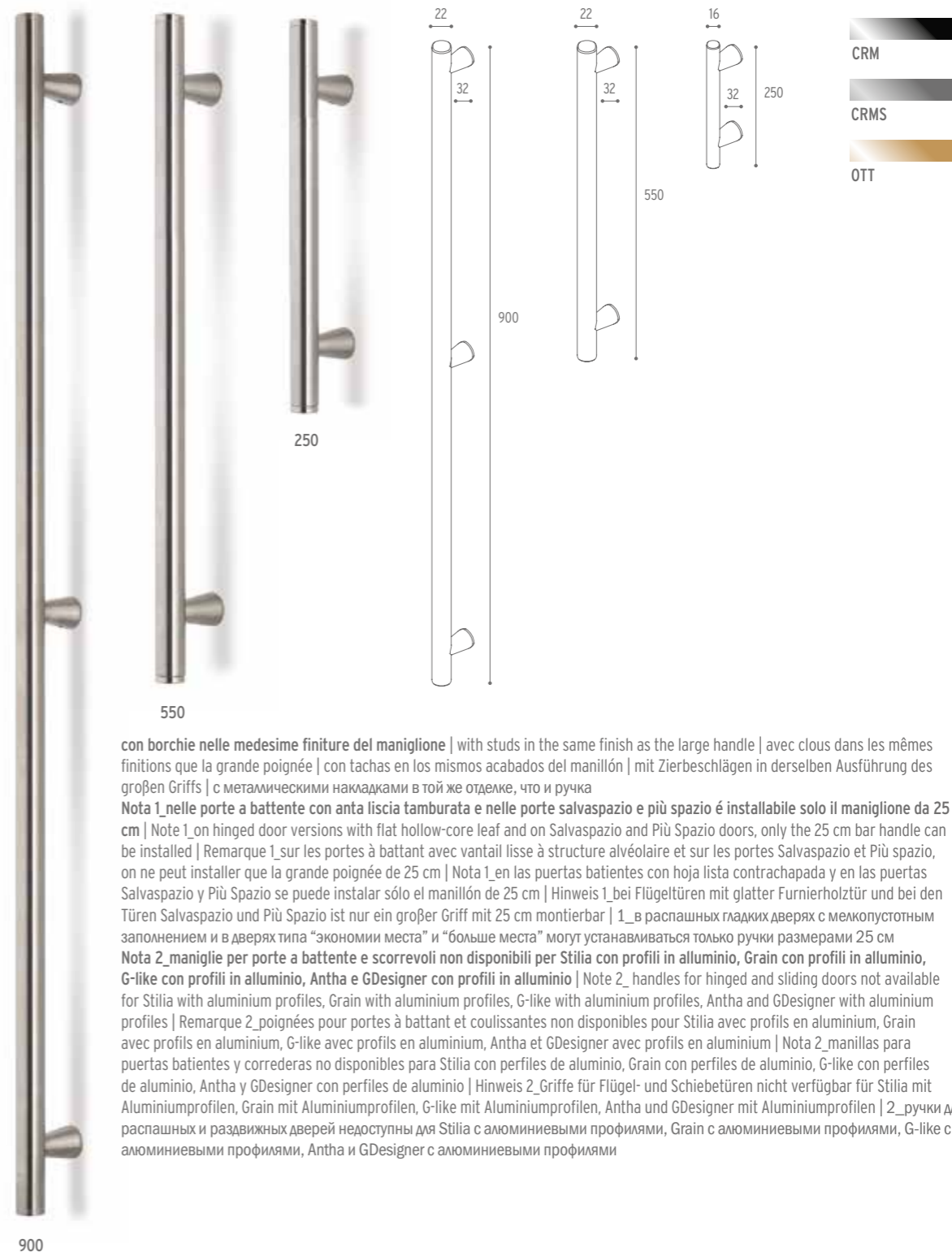



con borchie nelle medesime finiture del maniglione | with studs in the same finish as the large handle | avec clous dans les mêmes finitions que la grande poignée | con tachas en los mismos acabados del manillón | mit Zierbeschlägen in derselben Ausführung des großen Griffs | с металлическими накладками в той же отделке, что и ручка

**Nota 1\_nelle porte a battente con anta liscia tamburata e nelle porte salvaspazio e più spazio é installabile solo il maniglione da 25 cm** | Note 1\_on hinged door versions with flat hollow-core leaf and on Salvaspazio and Più Spazio doors, only the 25 cm bar handle can be installed | Remarque 1\_sur les portes à battant avec vantail lisse à structure alvéolaire et sur les portes Salvaspazio et Più spazio, on ne peut installer que la grande poignée de 25 cm | Nota 1\_en las puertas batientes con hoja lista contrachapada y en las puertas Salvaspazio y Più Spazio se puede instalar sólo el manillón de 25 cm | Hinweis 1\_bei Flügeltüren mit glatter Furnierholztür und bei den Türen Salvaspazio und Più Spazio ist nur ein großer Griff mit 25 cm montierbar | 1\_в распашных гладких дверях с мелкопустотным заполнением и в дверях типа “экономии места” и “больше места” могут устанавливаться только ручки размерами 25 см

**Nota 2\_maniglie per porte a battente e scorrevoli non disponibili per Stilia con profili in alluminio, Grain con profili in alluminio, G-like con profili in alluminio, Antha e GDesigner con profili in alluminio** | Note 2\_handles for hinged and sliding doors not available for Stilia with aluminium profiles, Grain with aluminium profiles, G-like with aluminium profiles, Antha and GDesigner with aluminium profiles | Remarque 2\_poignées pour portes à battant et coulissantes non disponibles pour Stilia avec profils en aluminium, Grain avec profils en aluminium, G-like avec profils en aluminium, Antha et GDesigner avec profils en aluminium | Nota 2\_manillas para puertas batientes y correderas no disponibles para Stilia con perfiles de aluminio, Grain con perfiles de aluminio, G-like con perfiles de aluminio, Antha y GDesigner con perfiles de aluminio | Hinweis 2\_Griffe für Flügel- und Schiebetüren nicht verfügbar für Stilia mit Aluminiumprofilen, Grain mit Aluminiumprofilen, G-like mit Aluminiumprofilen, Antha und GDesigner mit Aluminiumprofilen | 2\_ручки для распашных и раздвижных дверей недоступны для Stilia с алюминиевыми профилями, Grain с алюминиевыми профилями, G-like с алюминиевыми профилями, Antha и GDesigner с алюминиевыми профилями

## MANIGLIONE CURVO 55/100 cm

 **porte a battente** hinged doors | portes à battant | puertas batiente | Flügeltüren | распашная дверь

 **porte scorrevoli** sliding doors | portes coulissantes | puertas correderas | Schiebetüren | раздвижные двери

 **armadi** wardrobes | armoires | armarios | Schränke | шкафы



**con borchie nelle medesime finiture del maniglione** | with studs in the same finish as the large handle | avec clous dans les mêmes finitions que la grande poignée | con tachas en los mismos acabados del manillón | mit Zierbeschlägen in derselben Ausführung des großen Griffs | с металлическими накладками в той же отделке, что и ручка

**Nota 1** non utilizzabile nella porta a battente con anta liscia tamburata e nelle porte salvaspazio e più spazio | Note 1 not usable on hinged doors with flat hollow-core panel and on Salvaspazio and Più Spazio doors | Remarque 1 utilisation impossible sur la porte à battant avec vantail lisse à structure alvéolaire et les portes Salvaspazio et Più spazio | Nota 1 no utilizable en las puertas batientes con hoja lista contrachapada y en las puertas Salvaspazio y Più Spazio | Hinweis 1 nicht verwendbar an Flügeltüren mit glatter Furnierholztür und bei den Türen Salvaspazio und Più Spazio | 1\_не может использоваться в распашных гладких дверях с мелкопустотным заполнением и в дверях типа “экономии места” и “больше места”

**Nota 2** maniglie per porte a battente e scorrevoli non disponibili per Stilia con profili in alluminio, Grain con profili in alluminio, G-like con profili in alluminio, Antha e GDesigner con profili in alluminio | Note 2 handles for hinged and sliding doors not available for Stilia with aluminium profiles, Grain with aluminium profiles, G-like with aluminium profiles, Antha and GDesigner with aluminium profiles | Remarque 2 poignées pour portes à battant et coulissantes non disponibles pour Stilia avec profils en aluminium, Grain avec profils en aluminium, G-like avec profils en aluminium, Antha et GDesigner avec profils en aluminium | Nota 2 manillas para puertas batientes y correderas no disponibles para Stilia con perfiles de aluminio, Grain con perfiles de aluminio, G-like con perfiles de aluminio, Antha y GDesigner con perfiles de aluminio | Hinweis 2 Griffe für Flügel- und Schiebetüren nicht verfügbar für Stilia mit Aluminiumprofilen, Grain mit Aluminiumprofilen, G-like mit Aluminiumprofilen, Antha und GDesigner mit Aluminiumprofilen | 2\_ручки для распашных и раздвижных дверей недоступны для Stilia с алюминиевыми профилями, Grain с алюминиевыми профилями, G-like с алюминиевыми профилями, Antha и GDesigner с алюминиевыми профилями

1000

## MANIGLIONE 516 attacco base conica/cilindrica

 **porte a battente** hinged doors | portes à battant | puertas batiente | Flügeltüren | распашная дверь

 **porte scorrevoli** sliding doors | portes coulissantes | puertas correderas | Schiebetüren | раздвижные двери

 **armadi** wardrobes | armoires | armarios | Schränke | шкафы

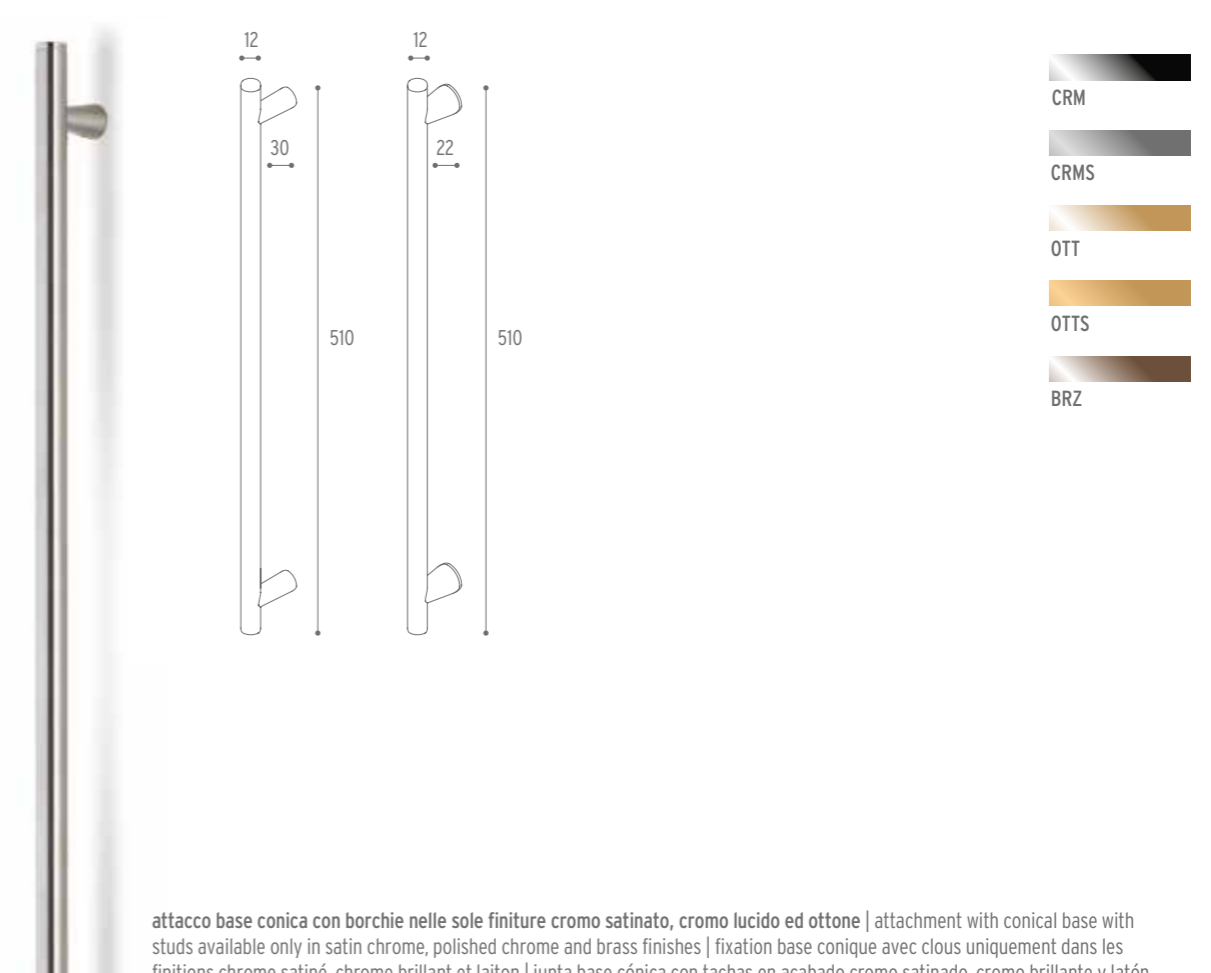

**attacco base conica con borchie nelle sole finiture cromo satinato, cromo lucido ed ottone** | attachment with conical base with studs available only in satin chrome, polished chrome and brass finishes | fixation base conique avec clous uniquement dans les finitions chrome satiné, chrome brillant et laiton | junta base cónica con tachas en acabado cromo satinado, cromo brillante y latón uñeros - manillas de uñero | Konischer Basisanschluss mit Zierbeschlägen nur in den Ausführungen Chrom satiniert, Chrom poliert und Messing | крепление конусообразной основы с металлическими накладками только в сатирированной хромированной, глянцевой хромированной и латунной отделке

**Nota 1** non utilizzabile nella porta a battente con anta liscia tamburata e nelle porte salvaspazio e più spazio | Note 1 not usable on hinged doors with flat hollow-core panel and on Salvaspazio and Più Spazio doors | Remarque 1 utilisation impossible sur la porte à battant avec vantail lisse à structure alvéolaire et les portes Salvaspazio et Più spazio | Nota 1 no utilizable en las puertas batientes con hoja lista contrachapada y en las puertas Salvaspazio y Più Spazio | Hinweis 1 nicht verwendbar an Flügeltüren mit glatter Furnierholztür und bei den Türen Salvaspazio und Più Spazio | 1\_не может использоваться в распашных гладких дверях с мелкопустотным заполнением и в дверях типа “экономии места” и “больше места”

**Nota 2** maniglie per porte a battente e scorrevoli non disponibili per Stilia con profili in alluminio, Grain con profili in alluminio, G-like con profili in alluminio, Antha e GDesigner con profili in alluminio | Note 2 handles for hinged and sliding doors not available for Stilia with aluminium profiles, Grain with aluminium profiles, G-like with aluminium profiles, Antha and GDesigner with aluminium profiles | Remarque 2 poignées pour portes à battant et coulissantes non disponibles pour Stilia avec profils en aluminium, Grain avec profils en aluminium, G-like avec profils en aluminium, Antha et GDesigner avec profils en aluminium | Nota 2 manillas para puertas batientes y correderas no disponibles para Stilia con perfiles de aluminio, Grain con perfiles de aluminio, G-like con perfiles de aluminio, Antha y GDesigner con perfiles de aluminio | Hinweis 2 Griffe für Flügel- und Schiebetüren nicht verfügbar für Stilia mit Aluminiumprofilen, Grain mit Aluminiumprofilen, G-like mit Aluminiumprofilen, Antha und GDesigner mit Aluminiumprofilen | 2\_ручки для распашных и раздвижных дверей недоступны для Stilia с алюминиевыми профилями, Grain с алюминиевыми профилями, G-like с алюминиевыми профилями, Antha и GDesigner с алюминиевыми профилями

## AREA 51

 **porte a battente** hinged doors | portes à battant | puertas batiente | Flügeltüren | распашная дверь

 **porte scorrevoli** sliding doors | portes coulissantes | puertas correderas | Schiebetüren | раздвижные двери

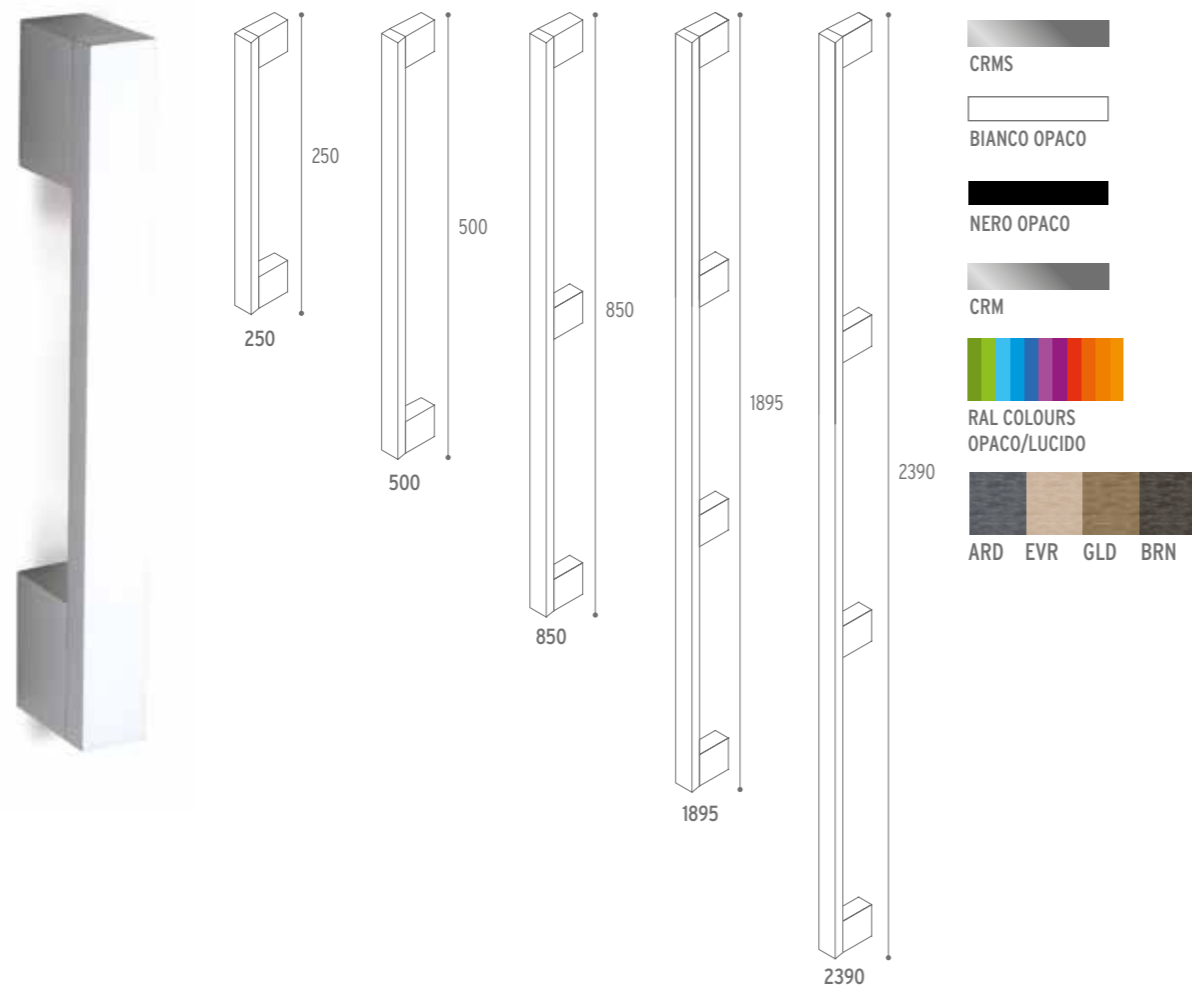

con borchie nelle medesime finiture del maniglione | with studs in the same finish as the large handle | avec clous dans les mêmes finitions que la grande poignée | con tachas en los mismos acabados del manillón | mit Zierbeschlägen in derselben Ausführung des großen Griffs | с металлических накладками в той же отделке, что и ручка

**Nota 1** non utilizzabile nella porta a battente con anta liscia tamburata e nelle porte salvaspazio e più spazio | Note 1 not usable on hinged doors with flat hollow-core panel and on Salvaspazio and Più Spazio doors | Remarque 1 utilisation impossible sur la porte à battant avec vantail lisse à structure alvéolaire et les portes Salvaspazio et Più spazio | Nota 1 no utilizable en las puertas batientes con hoja lista contrachapada y en las puertas Salvaspazio y Più Spazio | Hinweis 1 nicht verwendbar an Flügeltüren mit glatter Furnierholztür und bei den Türen Salvaspazio und Più Spazio | 1 не может использоваться в распашных гладких дверях с мелкопустотным заполнением и в дверях типа "экономии места" и "больше места"

**Nota 2** maniglie per porte a battente e scorrevoli non disponibili per Stilia con profili in alluminio, Grain con profili in alluminio, G-like con profili in alluminio, Antha e GDesigner con profili in alluminio | Note 2 handles for hinged and sliding doors not available for Stilia with aluminium profiles, Grain with aluminium profiles, G-like with aluminium profiles, Antha and GDesigner with aluminium profiles | Remarque 2 poignées pour portes à battant et coulissantes non disponibles pour Stilia avec profils en aluminium, Grain avec profils en aluminium, G-like avec profils en aluminium, Antha et GDesigner avec profils en aluminium | Nota 2 manillas para puertas batientes y correderas no disponibles para Stilia con perfiles de aluminio, Grain con perfiles de aluminio, G-like con perfiles de aluminio, Antha y GDesigner con perfiles de aluminio | Hinweis 2 Griffe für Flügel- und Schiebetüren nicht verfügbar für Stilia mit Aluminiumprofilen, Grain mit Aluminiumprofilen, G-like mit Aluminiumprofilen, Antha und GDesigner mit Aluminiumprofilen | 2 ручки для распашных и раздвижных дверей недоступны для Stilia с алюминиевыми профилями, Grain с алюминиевыми профилями, G-like с алюминиевыми профилями, Antha и GDesigner с алюминиевыми профилями

## FREEN

 **porte a battente** hinged doors | portes à battant | puertas batiente | Flügeltüren | распашная дверь

 **porte scorrevoli** sliding doors | portes coulissantes | puertas correderas | Schiebetüren | раздвижные двери

CRM CRMS

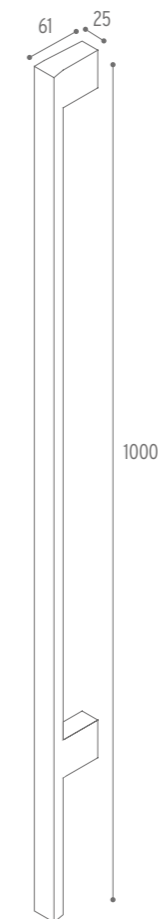

## MANIGLIONE SIRIO

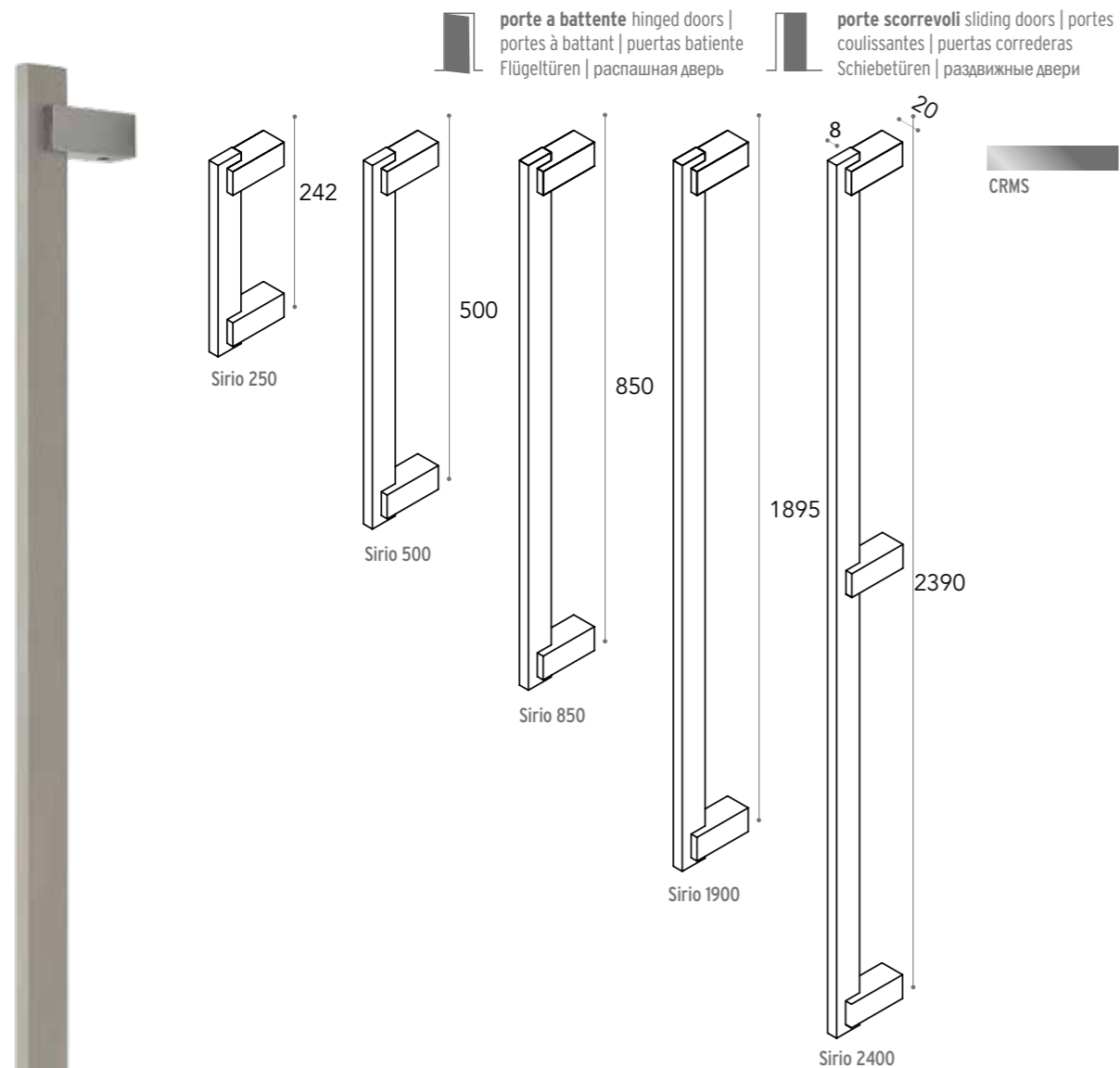

Nota 1\_non utilizzabile nella porta a battente con anta liscia tamburata e nelle porte salvaspazio e più spazio | Note 1\_not usable on hinged doors with flat hollow-core panel and on Salvaspazio and Più Spazio doors | Remarque 1\_utilisation impossible sur la porte à battant avec vantail lisse à structure alvéolaire et les portes Salvaspazio et Più spazio | Nota 1\_no utilizable en las puertas batientes con hoja lista contrachapada y en las puertas Salvaspazio y Più Spazio | Hinweis 1\_nicht verwendbar an Flügeltüren mit glatter Furnierholztür und bei den Türen Salvaspazio und Più Spazio | 1\_не может использоваться в распашных гладких дверях с мелкопустотным заполнением и в дверях типа “экономии места” и “больше места”

Nota 2\_maniglie per porte a battente e scorrevoli non disponibili per Stilia con profili in alluminio, Grain con profili in alluminio, G-like con profili in alluminio, Antha e GDesigner con profili in alluminio | Note 2\_handles for hinged and sliding doors not available for Stilia with aluminium profiles, Grain with aluminium profiles, G-like with aluminium profiles, Antha and GDesigner with aluminium profiles | Remarque 2\_poignées pour portes à battant et coulissantes non disponibles pour Stilia avec profils en aluminium, Grain avec profils en aluminium, G-like avec profils en aluminium, Antha et GDesigner avec profils en aluminium | Nota 2\_manillas para puertas batientes y correderas no disponibles para Stilia con perfiles de aluminio, Grain con perfiles de aluminio, G-like con perfiles de aluminio, Antha y GDesigner con perfiles de aluminio | Hinweis 2\_Griffe für Flügelt- und Schiebetüren nicht verfügbar für Stilia mit Aluminiumprofilen, Grain mit Aluminiumprofilen, G-like mit Aluminiumprofilen, Antha und GDesigner mit Aluminiumprofilen | 2\_ручки для распашных и раздвижных дверей недоступны для Stilia с алюминиевыми профилями, Grain с алюминиевыми профилями, G-like с алюминиевыми профилями, Antha и GDesigner с алюминиевыми профилями

## MANIGLIONE DESIGN



installabile solo su Stilia con profili in alluminio, Grain con profili in alluminio, Rubia, Filomuro, Glike e Gdesigner | installable only on Stilia with aluminium profiles, Grain with aluminium profiles, Rubia, Filomuro, Glike and GDesigner | installation possible uniquement sur les portes Stilia avec profils en aluminium, Grain avec profils en aluminium, Rubia, Filomuro, Glike et Gdesigner | instalable sólo en Stilia con perfiles de aluminio, Grain con perfiles de aluminio, Rubia, Filomuro, Glike y Gdesigner | Nur montierbar auf Stilia mit Aluminiumprofilen, Grain mit Aluminiumprofilen, Rubia, Filomuro, Glike und Gdesigner | может устанавливаться только на Stilia с алюминиевыми профилями, Grain с алюминиевыми профилями, Rubia, Filomuro, Glike и Gdesigner

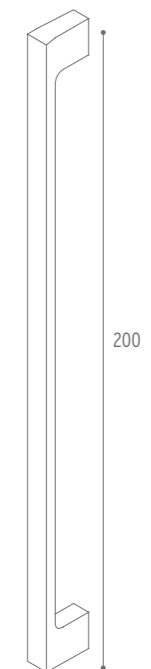

## MANIGLIONE ICE

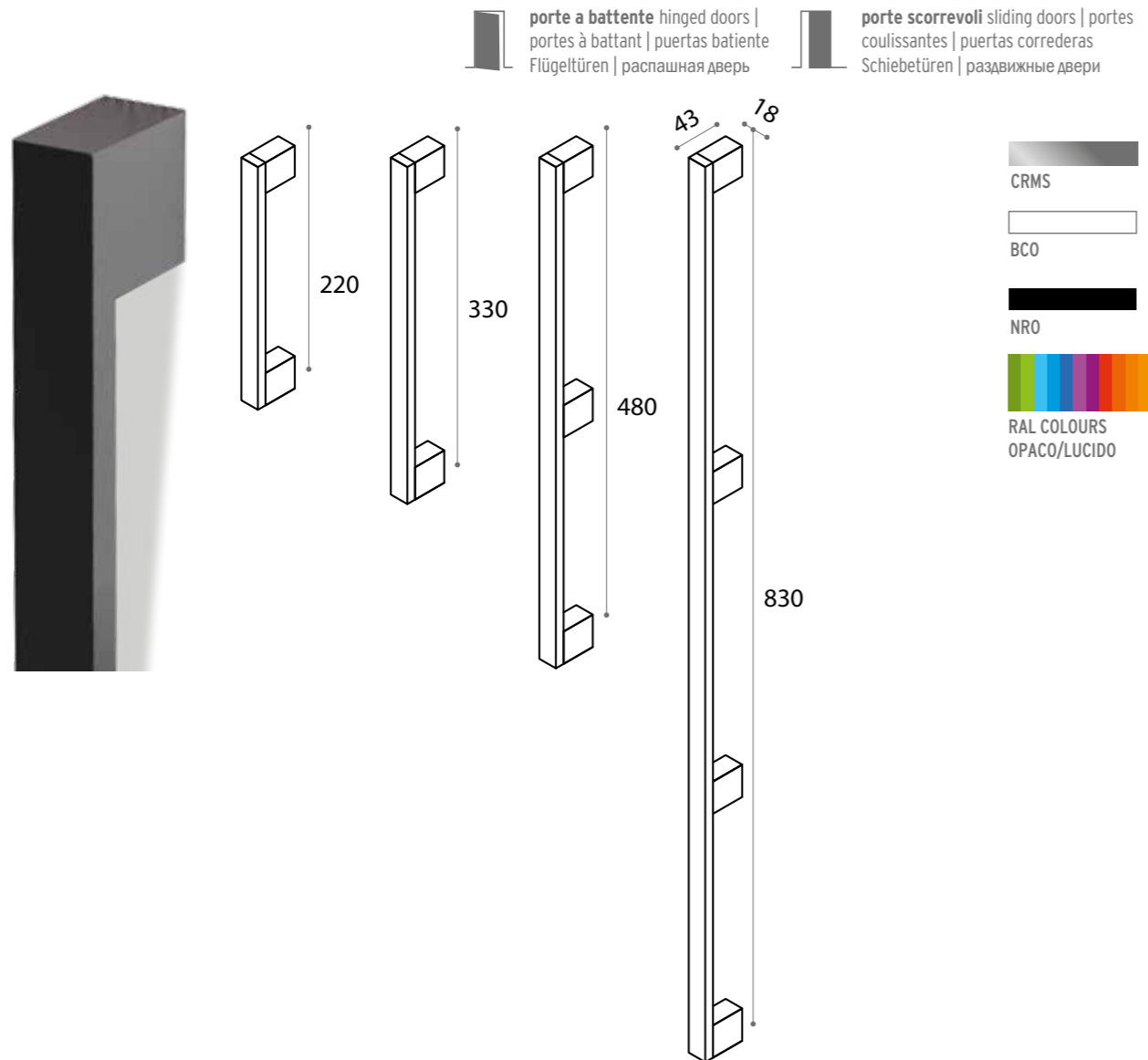

Nota 1\_non utilizzabile nella porta a battente con anta liscia tamburata e nelle porte salvaspazio e più spazio | Note 1\_not usable on hinged doors with flat hollow-core panel and on Salvaspazio and Più Spazio doors | Remarque 1\_utilisation impossible sur la porte à battant avec vantail lisse à structure alvéolaire et les portes Salvaspazio et Più spazio | Nota 1\_no utilizable en las puertas batientes con hoja lista contrachapada y en las puertas Salvaspazio y Più Spazio | Hinweis 1\_nicht verwendbar an Flügeltüren mit glatter Furnierholztür und bei den Türen Salvaspazio und Più Spazio | 1\_не может использоваться в распашных гладких дверях с мелкопустотным заполнением и в дверях типа “экономии места” и “больше места”

Nota 2\_maniglie per porte a battente e scorrevoli non disponibili per Stilia con profili in alluminio, Grain con profili in alluminio, G-like con profili in alluminio, Antha e GDesigner con profili in alluminio | Note 2\_handles for hinged and sliding doors not available for Stilia with aluminium profiles, Grain with aluminium profiles, G-like with aluminium profiles, Antha and GDesigner with aluminium profiles | Remarque 2\_poignées pour portes à battant et coulissantes non disponibles pour Stilia avec profils en aluminium, Grain avec profils en aluminium, G-like avec profils en aluminium, Antha et GDesigner avec profils en aluminium | Nota 2\_manillas para puertas batientes y correderas no disponibles para Stilia con perfiles de aluminio, Grain con perfiles de aluminio, G-like con perfiles de aluminio, Antha y GDesigner con perfiles de aluminio | Hinweis 2\_Griffe für Flügell- und Schiebetüren nicht verfügbar für Stilia mit Aluminiumprofilen, Grain mit Aluminiumprofilen, G-like mit Aluminiumprofilen, Antha und GDesigner mit Aluminiumprofilen | 2\_ручки для распашных и раздвижных дверей недоступны для Stilia с алюминиевыми профилями, Grain с алюминиевыми профилями, G-like с алюминиевыми профилями, Antha и GDesigner с алюминиевыми профилями

## MANIGLIONE T240/T390/T540

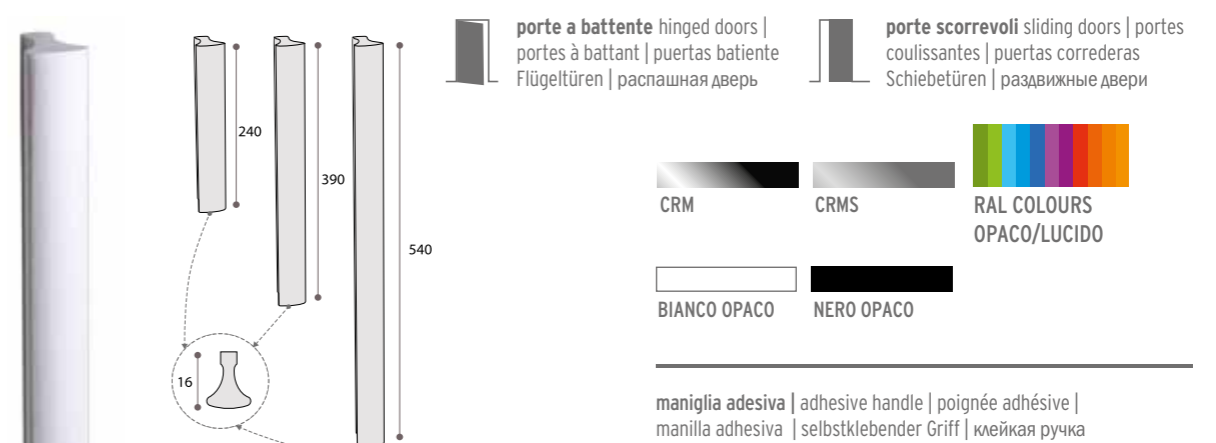

## MANIGLIONE L240/L390/L540

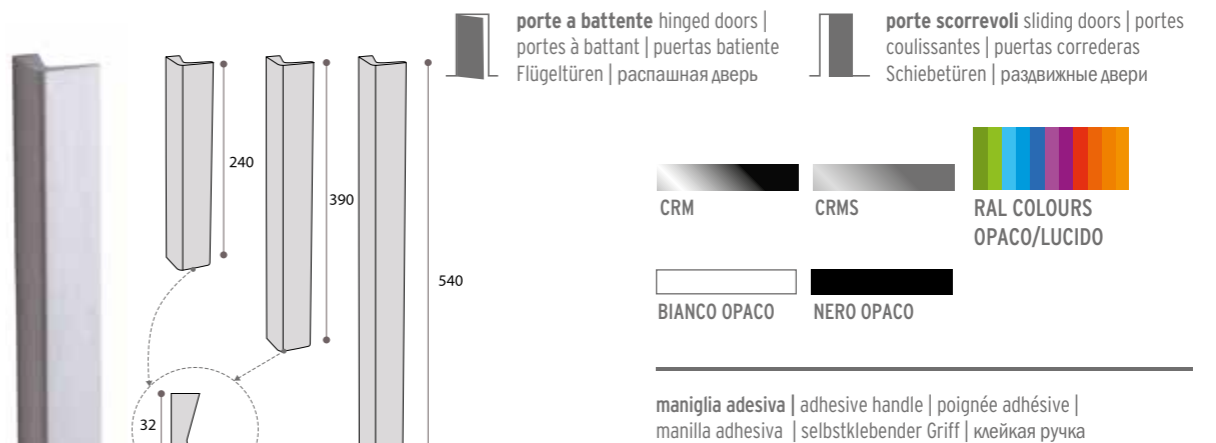

## HOLE



## VASCHETTA CIRCOLARE + PLACCA QUADRATA

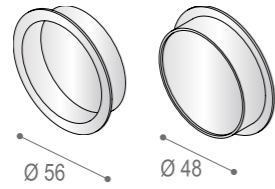

porte scorrevoli sliding doors | portes coulissantes | puertas correderas  
 Schiebetüren | раздвижные двери

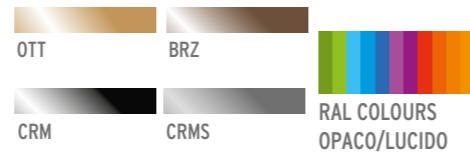

## VASCHETTA QUADRATA + PLACCA QUADRATA

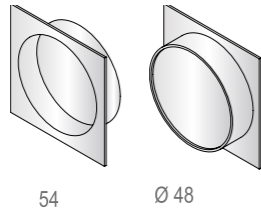

porte scorrevoli sliding doors | portes coulissantes | puertas correderas  
 Schiebetüren | раздвижные двери

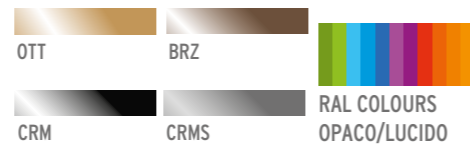

## VASCHETTA CIRCOLARE + PLACCA RETTANGOLARE

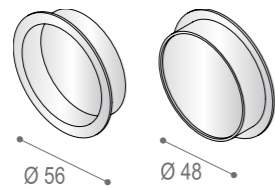

porte scorrevoli sliding doors | portes coulissantes | puertas correderas  
 Schiebetüren | раздвижные двери

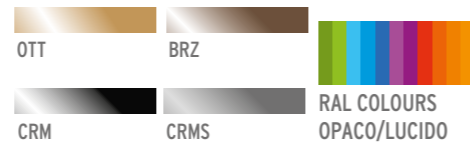

## VASCHETTA QUADRATA + PLACCA RETTANGOLARE

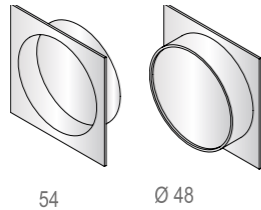

porte scorrevoli sliding doors | portes coulissantes | puertas correderas  
 Schiebetüren | раздвижные двери

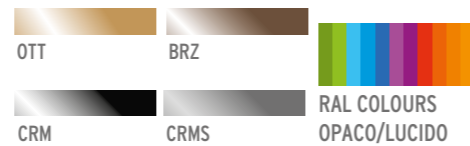

## VASCHETTA CON SERRATURA A NOTTOLINO + PLACCA RETTANGOLARE E QUADRATA

porte scorrevoli sliding doors | portes coulissantes | puertas correderas  
 Schiebetüren | раздвижные двери

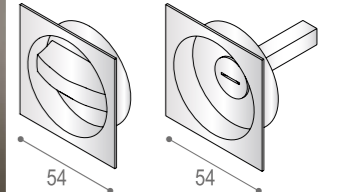
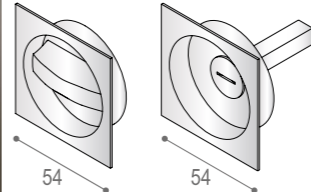
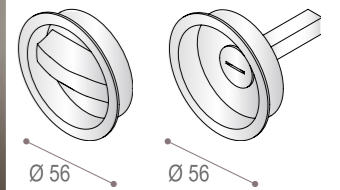
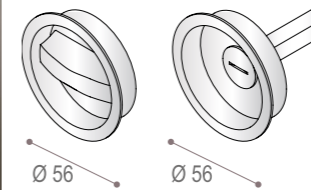
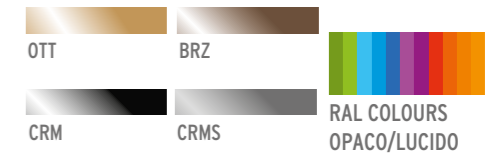

## VASCHETTA CON SERRATURA YALE + PLACCA RETTANGOLARE

porte scorrevoli sliding doors | portes coulissantes | puertas correderas  
 Schiebetüren | раздвижные двери

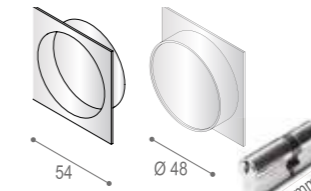
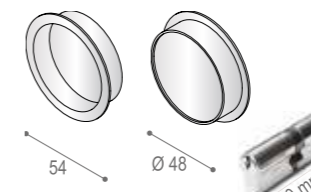
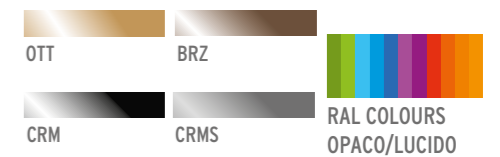

## TONDA

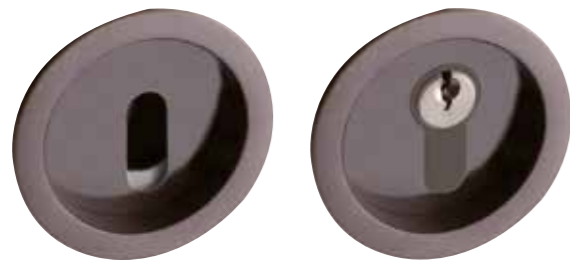

con serratura patent

con serratura yale



con nottolino

senza serratura

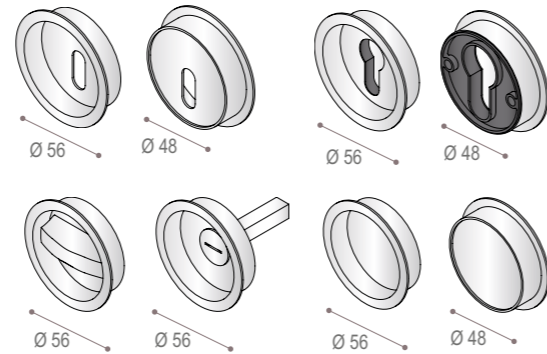

## QUADRATA



con serratura patent

con serratura yale



con nottolino

senza serratura

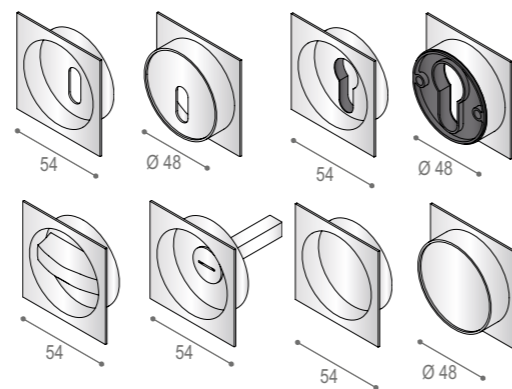
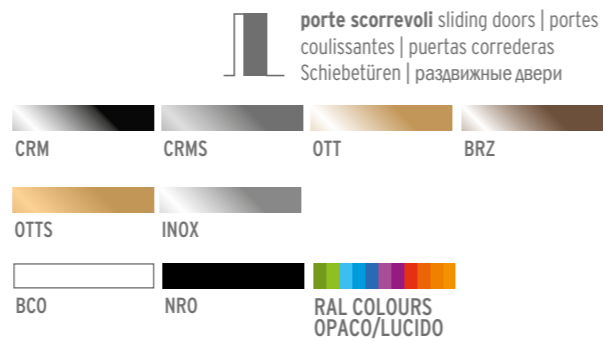

## PAMAR



**porte a battente** hinged doors | portes à battant | puertas batiente | Flügeltüren | распашная дверь

**armadi** wardrobes | armoires | armarios | Schränke | шкафы

**porte a fisarmonica** accordion doors | portes accordéon | puertas plegables en acordeón | Ziehharmonika-Türen | дверь-гармошка

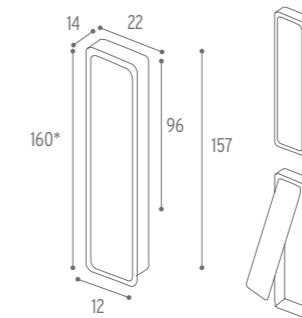

## G-LINE



**porte a battente** hinged doors | portes à battant | puertas batiente | Flügeltüren | распашная дверь

**armadi** wardrobes | armoires | armarios | Schränke | шкафы



Disponibile sia per chiusura con nottolino o chiave, sia in versione solo con tiretto | Available both for locking with a latch or key, and as a pull-only version | Disponible version fermeture avec loquet ou clé, ou version uniquement escamotable | Disponible para cierre con pasador, con llave o solo con tirador | Erhältlich sowohl mit Klinkhaken oder abschließbar als auch in Ausführung mit einfacher Zuglasche | Доступно как для закрытия с помощью защелки или ключа, так и в версии только с выдвигаемым элементом

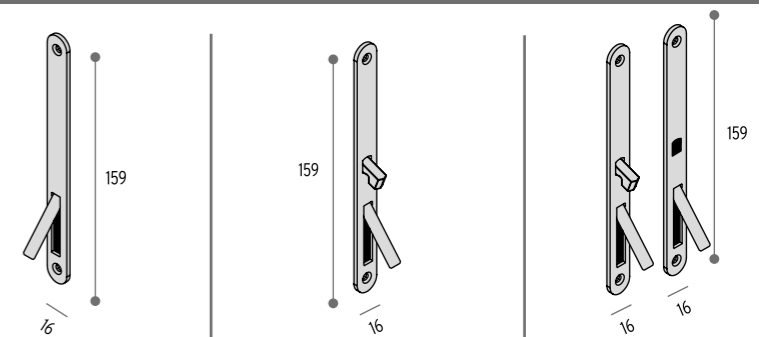

## RETTANGOLARE INCASSATA

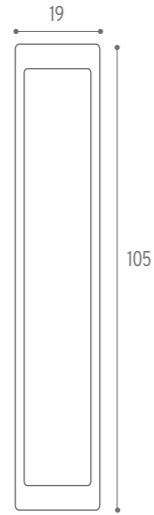

**porte scorrevoli** sliding doors | portes coulissantes | puertas correderas | Schiebetüren | раздвижные двери  
**armadi** wardrobes | armoires | armarios | Schränke | шкафы



Disponibile solo per porte modello "Ive" | Only available for "Ive" doors | Disponible uniquement pour portes modèle «Ive» | Disponible solo para puertas modelo «Ive» | Erhältlich nur für das Türmodell „Ive“ | Доступно только для дверей модели Ive

## VASCHETTA A FILO



**porte scorrevoli** sliding doors | portes coulissantes | puertas correderas | Schiebetüren | раздвижные двери

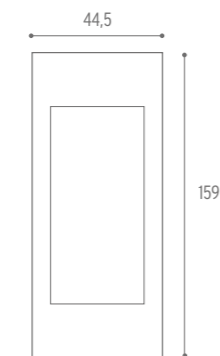

disponibile solo per Bisystem | available only for Bisystem | disponible uniquement pour Bisystem | disponible sólo para Bisystem | nur erhältlich für Bisystem | доступно только для Bisystem

## R150



**porte scorrevoli** sliding doors | portes coulissantes | puertas correderas | Schiebetüren | раздвижные двери

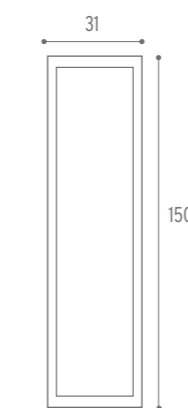

disponibile solo per Bisystem | available only for Bisystem | disponible uniquement pour Bisystem | disponible sólo para Bisystem | nur erhältlich für Bisystem | доступно только для Bisystem

## R150 per DSF



**porte scorrevoli** sliding doors | portes coulissantes | puertas correderas | Schiebetüren | раздвижные двери

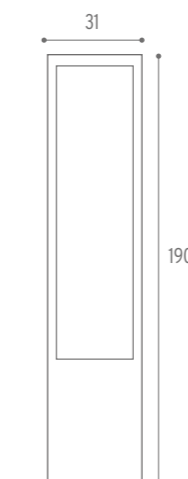

disponibile solo per Bisystem | available only for Bisystem | disponible uniquement pour Bisystem | disponible sólo para Bisystem | nur erhältlich für Bisystem | доступно только для Bisystem

## R150 YALE

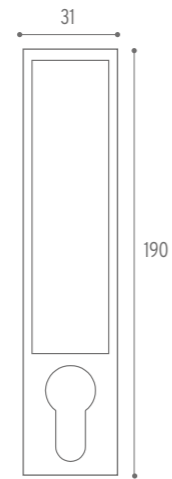
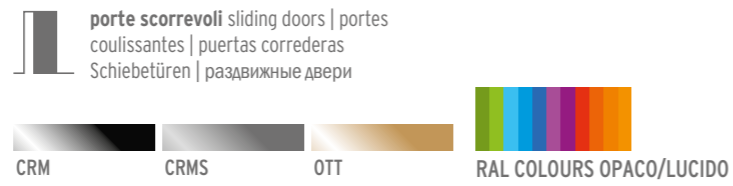

disponibile solo per Bisystem | available only for Bisystem  
 | disponible uniquement pour Bisystem | disponible sólo para Bisystem | nur erhältlich für Bisystem | доступно только для Bisystem

## R150 NOTTOLINO

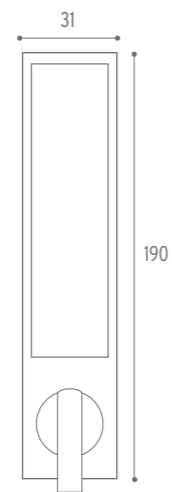

disponibile solo per Bisystem | available only for Bisystem  
 | disponible uniquement pour Bisystem | disponible sólo para Bisystem | nur erhältlich für Bisystem | доступно только для Bisystem

## R150 A FILO

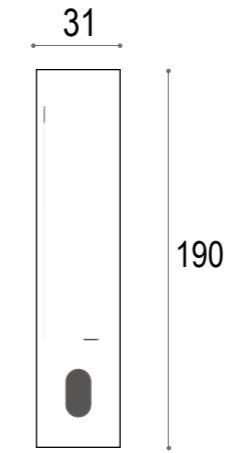
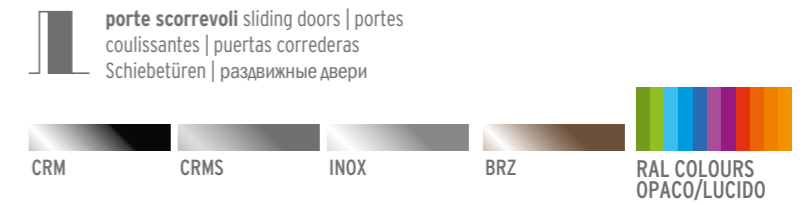

disponibile solo per Bisystem | available only for Bisystem  
 | disponible uniquement pour Bisystem | disponible sólo para Bisystem | nur erhältlich für Bisystem | доступно только для Bisystem

## R150 CON CHIAVE RIGIDA

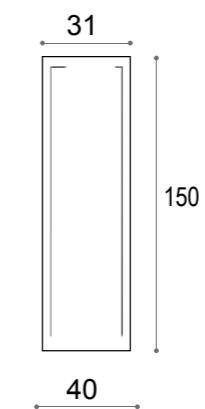
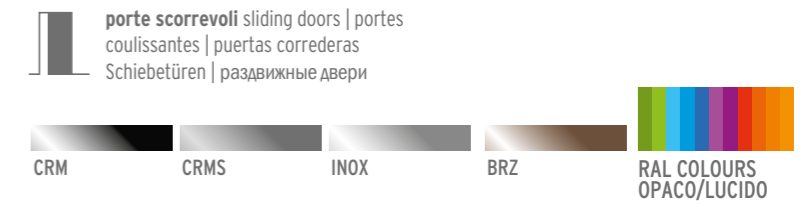

disponibile solo per Bisystem | available only for Bisystem  
 | disponible uniquement pour Bisystem | disponible sólo para Bisystem | nur erhältlich für Bisystem | доступно только для Bisystem

## OCCHIELLO TIRAPORTA RETTANGOLARE

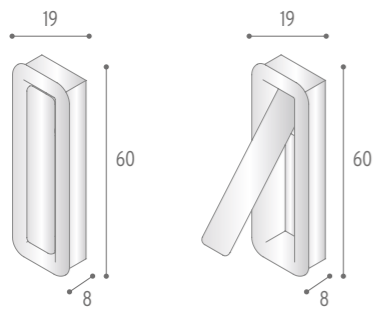

installabile solo su Stilia con profili in alluminio, Grain con profili in alluminio, 1M2007, Rubia, Filomuro e Gdesigner | installable only on Stilia with aluminium profiles, Grain with aluminium profiles, 1M2007, Rubia, Filomuro and Gdesigner | installation possible uniquement sur les portes Stilia avec profils en aluminium, Grain avec profils en aluminium, 1M2007, Rubia, Filomuro et Gdesigner | instalable sólo en Stilia con perfiles de aluminio, Grain con perfiles de aluminio, 1M2007, Rubia, Filomuro y Gdesigner | Nur montierbar auf Stilia mit Aluminiumprofilen, Grain mit Aluminiumprofilen, 1M2007, Rubia, Filomuro und Gdesigner | может устанавливаться только на Stilia с алюминиевыми профилями, Grain с алюминиевыми профилями, 1M2007, Rubia, Filomuro и Gdesigner

## C54 VASCHETTA AD INCASSO

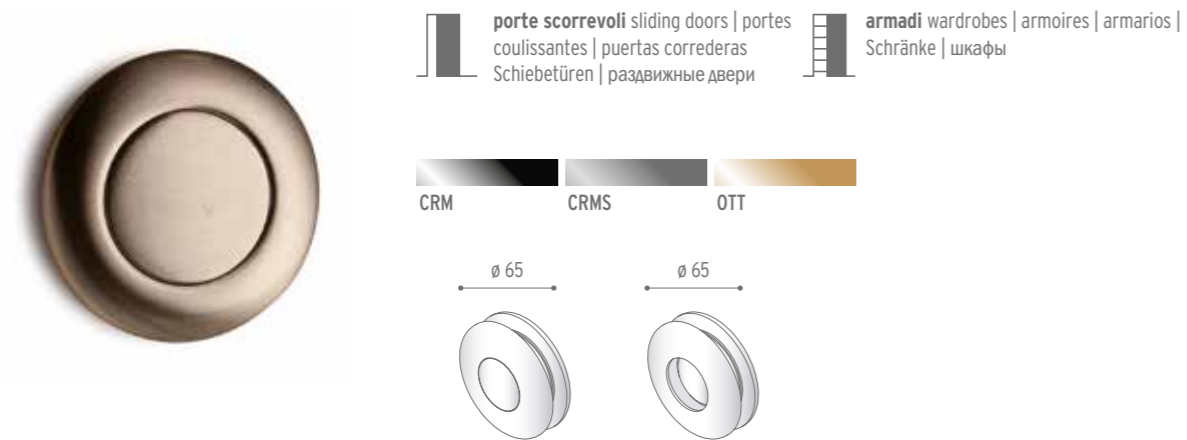

## KIT PORTA A LIBRO

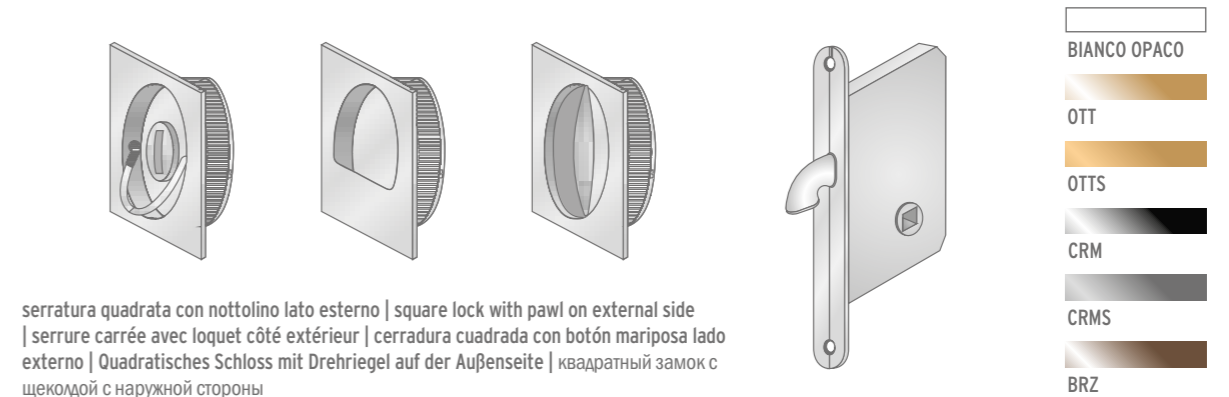
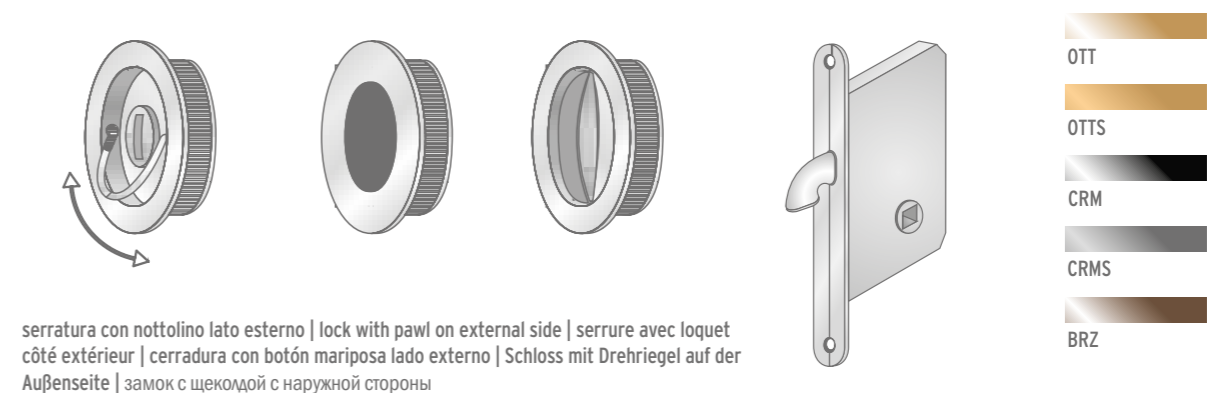
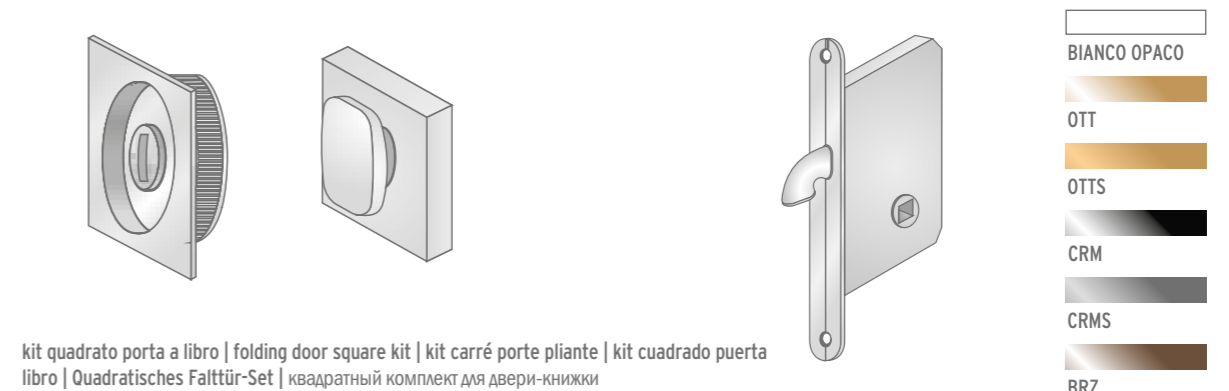

## GRIGLIE DI AREAZIONE

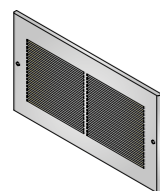

GRIGLIA IN METALLO 240 X 140  
 Dimensioni esterne: 240x140 mm;  
 Spessore: 5 mm  
 Sezione di passaggio aria: 80 cm<sup>2</sup>  
 Montaggio std  
 per misure convenzionali  
 550 + L < 650

 **porte a battente** hinged doors  
 | portes à battant | puertas batiente  
 | Flügeltüren | распашная дверь

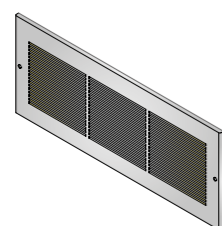

GRIGLIA IN METALLO 340 X 140  
 Dimensioni esterne: 340x140 mm;  
 Spessore: 5 mm  
 Sezione di passaggio aria: 120 cm<sup>2</sup>  
 Montaggio std  
 per misure convenzionali  
 650 + L < 750

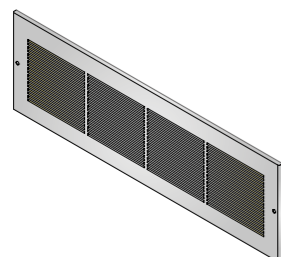

GRIGLIA IN METALLO 440 X 140  
 Dimensioni esterne: 440x140 mm;  
 Spessore: 5 mm  
 Sezione di passaggio aria: 160 cm<sup>2</sup>  
 Montaggio std  
 per misure convenzionali  
 750 + L < 850

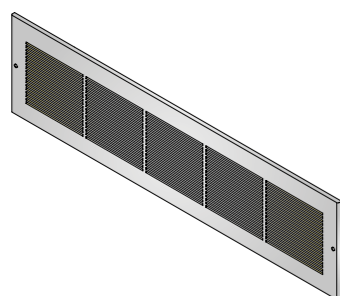

GRIGLIA IN METALLO 540 X 140  
 Dimensioni esterne: 540x140 mm;  
 Spessore: 5 mm  
 Sezione di passaggio aria: 200 cm<sup>2</sup>  
 Montaggio std  
 per misure convenzionali  
 L + 850

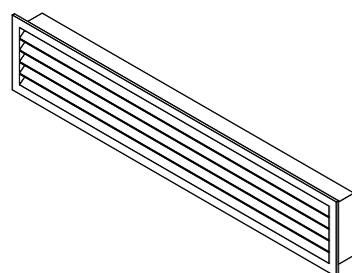

GRIGLIA IN PLASTICA 452 X 90  
 Dimensioni esterne: 452 x 90 mm;  
 Spessore: 3 mm  
 Sezione di passaggio aria: 200 cm<sup>2</sup>  
 Per misure convenzionali  
 per anta liscia L + 600  
 per anta bugnata L + 700  
 Spessore pannello su cui installare  
 la griglia  
 28 mm min - 44 mm max



## LAMA TAGLIA FREDDO

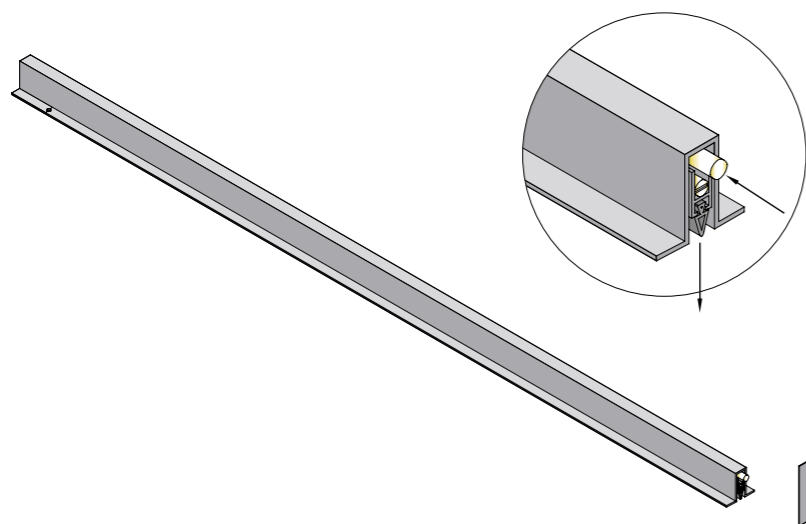

**porte a battente** hinged doors  
| portes à battant | puertas batiente  
| Flügeltüren | распашная дверь

CRMS

La lama è inserita in una fresata nella parte inferiore dell'anta. Chiudendo l'anta, il pulsante si preme contro la piastra installata sul telaio, facendo abbassare la barra mobile con la lama in gomma | The draught excluder is inserted in a milled groove along the lower section of the door leaf. When closing the door, the button presses against the plate fixed to the frame, causing the mobile bar with the rubber blade to lower. | La lame est insérée dans un fraisage dans la partie inférieure de la porte. Lorsque l'on ferme la porte, le bouton appuie contre la plaque installée sur le cadre, faisant s'abaisser la barre mobile avec la lame en caoutchouc | El perfil se inserta en un fresado en la parte inferior de la hoja. Al cierre de la hoja, el pulsador se presiona contra la placa instalada en el marco y hace bajar la barra móvil con el perfil de goma | Die Dichtung ist in die Fräsung im unteren Bereich des Türflügels eingefügt. Beim Schließen der Tür drückt der Knopf gegen die an der Zarge montierten Platte, wodurch der bewegliche Stab mit der Gummidichtung abgesenkt wird | Пластика вставлена в фрезерованную прорезь в нижней части створки. При закрытии створки кнопка нажимает на накладку, установленную на раме, что приводит к опусканию подвижного стержня с резиновой пластинкой

non installabile su ante con profili in alluminio, Miria, porte senza traversa inferiore | not installable on doors with aluminium profiles, Miria, doors without lower crossbeam | installation impossible sur les portes avec profils en aluminium, Miria, portes sans traverse inférieure | no instalable en hojas con perfiles de aluminio, Miria, puertas sin travesaño inferior | Nicht montierbar auf Türen mit Aluminiumprofilen, Miria und Türen ohne unteren Querträger | не устанавливается на створках с алюминиевыми профилями, на моделях Miria, на дверях без нижней перекладины

## SPIONCINO "OCCHIO MAGICO"



**porte a battente** hinged doors  
| portes à battant | puertas batiente  
| Flügeltüren | распашная дверь

CRMS OTT

## MANIGLIONE ANTIPANICO PUSH BAR



tipo ISEO



tipo CISA

**porte a battente** hinged doors  
| portes à battant | puertas batiente  
| Flügeltüren | распашная дверь

consultare listini per fattibilità tecnica  
| consult the price lists for the technical  
feasibility | consulter les catalogues pour en  
savoir sur la faisabilité technique | consultar  
los catálogos para la factibilidad técnica  
| Konsultieren Sie die Preislisten in Bezug auf  
die technische Machbarkeit | в отношении  
технических возможностей реализации  
обратиться к прайс-листам

## MANIGLIONE ANTIPANICO A BARRA



tipo CISA



tipo SLASH



tipo EXUS



**porte a battente** hinged doors  
| portes à battant | puertas batiente  
| Flügeltüren | распашная дверь

consultare listini per fattibilità tecnica  
| consult the price lists for the technical  
feasibility | consulter les catalogues pour en  
savoir sur la faisabilité technique | consultar  
los catálogos para la factibilidad técnica  
| Konsultieren Sie die Preislisten in Bezug auf  
die technische Machbarkeit | в отношении  
технических возможностей реализации  
обратиться к прайс-листам

## LIMITATORE DI APERTURA A SCOMPARSA

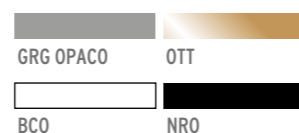
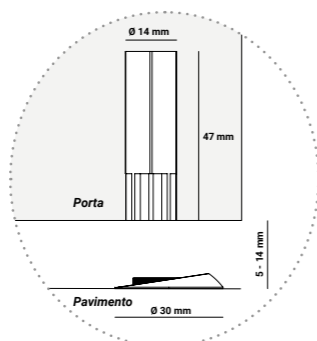

## LIMITATORE DI APERTURA A VISTA

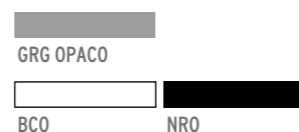

## LIMITATORE DI APERTURA CON APPENDIABILI



## LIMITATORI DI APERTURA E FERMAPORTA

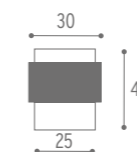

porte a battente hinged doors  
| portes à battant | puertas batiente  
| Flügeltüren | распашная дверь



L5 Limitatore di apertura per porte a battente 'stop a terra' mod. cilindrico | L5 - door stop for hinged door cylindrical model | L5 - limiteur d'ouverture pour portes à battant mod. cylindrique | L5 - limitador de apertura para puertas batientes mod. cilindrico | L5 - öffnungsbegrenzer für flügeltüren, modell zylinder | L5 - ограничитель открытия для распашной двери мод. цилиндrico

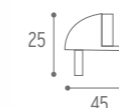

porte a battente hinged doors  
| portes à battant | puertas batiente  
| Flügeltüren | распашная дверь



L6 Limitatore di apertura per porte a battente 'stop a terra' mod. chiocciola | L6 - door stop for hinged door snail model | L6 - limiteur d'ouverture pour portes à battant mod. escargot | L6 - limitador de apertura para puertas batientes mod. caracol | L6 - öffnungsbegrenzer für flügeltüren, modell schnecke | L6 - ограничитель открытия для распашной двери мод. chiocciola

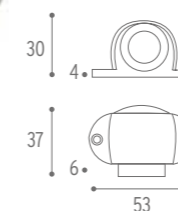

porte a battente hinged doors  
| portes à battant | puertas batiente  
| Flügeltüren | распашная дверь



L7 Limitatore di apertura per porte a battente 'stop a terra' mod. magnetico | L7 - door stop for hinged door magnetic model | L7 - limiteur d'ouverture pour porte à battant mod. magnétique | L7 - limitador de apertura para puertas batientes mod. magnético | L7 - öffnungsbegrenzer für flügeltüren, modell magnet | L7 - ограничитель открытия для распашной двери мод. magnetico



porte a battente hinged doors  
| portes à battant | puertas batiente  
| Flügeltüren | распашная дверь



L9 Limitatore di apertura per porte a battente 'stop su maniglia' mod. salvamaniglia | L9 - door stop for hinged door handle guard model | L9 - limiteur d'ouverture pour porte à battant mod. protège-poignée | L9 - limitador de apertura para puertas batientes mod. salvamanilla | L9 - öffnungsbegrenzer für flügeltüren, modell griffschutz | L9 - ограничитель открытия для распашной двери мод. salvamaniglia

## SENSORE STATO PORTA



## PITTOGRAMMI



INOX

## TARGHETTE CAMERA



**Cornice verticale** | Vertical frame | Cadre vertical | Marco vertical | Vertikaler Rahmen | Вертикальная рамка



**Numeri singoli grandi** | Large single numbers | Numéros individuels grands | Números individuales grandes | Einzelne große Nummern | Большие отдельные цифры



**Numeri per corridoi** | Numbers for hallways | Numéros pour couloirs | Números para pasillos | Flurnummern | Цифры для коридоров дверь



**Numeri per corridoi a placca** | Number plates | Numéros pour couloirs sur plaque | Números en placas para pasillos | Schild mit Flurnummern | Табличка с цифрами для коридоров

## PLACCA PARACOLPI



**porte a battente** | hinged doors | portes à battant | puertas batiente | Flügeltüren | распашная дверь

CRMS

é possibile ordinare su misura placche paracolpi | custom-size impact guard panels can be ordered | il est possible de commander des plaques pare-chocs sur mesure | es posible pedir placas parachoques a medida | Es können Stoßschutz-Platten nach Maß bestellt werden | имеется возможность заказать под размер буферные накладки





FIRMA LE VERE PORTE IN LEGNO MASSICCIO

**Garofoli SpA**

Via Recanatense 37  
60022 Castelfidardo  
AN Italia  
tel. +39 071 72 71 71  
fax +39 071 78 03 80  
info@garofoli.com  
www.garofoli.com

**GIDEA**

new generation doors

**Gidea Srl**

Via Pignini 59  
60022 Castelfidardo  
AN Italia  
T +39 071 72 06 830  
F +39 071 72 06 838  
info@gidea.it  
www.gidea.it



Per scoprire novità, prodotti  
e soluzioni scansiona il QR Code.  
Scan the QR Code to discover news,  
products and solutions.